

# GDN Water Treatment

## HERE WE ARE



**GDN Water Treatment in Soresina is a company formed by professionals that have more than 40 years of experience in the manufacture of equipments for water production, from sea water to pre-treatment plants, from Reverse Osmosis to Distillation equipments, water storage, mixing and distribution.**

**This technology comes from long years of activity developed in major manufacturing companies specialized in water treatment and we mainly aim at 2 goals:**

**-the research and the development of the technological innovation of the machineries according to the continuous changes in the international rules of the sector**

**-giving support, through our own work and experience, to the customer production requirements and philosophy, trying to relieve him as much as possible from the tasks and activities concerning the equipment and the materials research, which can often distract him from his main activity.**

### **GDN SRL**

Via Cremona, 12  
26015 Soresina (CR), Italy  
Tel +39 0374 870515 Fax +39 0374 341863  
[www.gdnsrl.it](http://www.gdnsrl.it) [info@gdnsrl.it](mailto:info@gdnsrl.it)

# OUR OFFICES

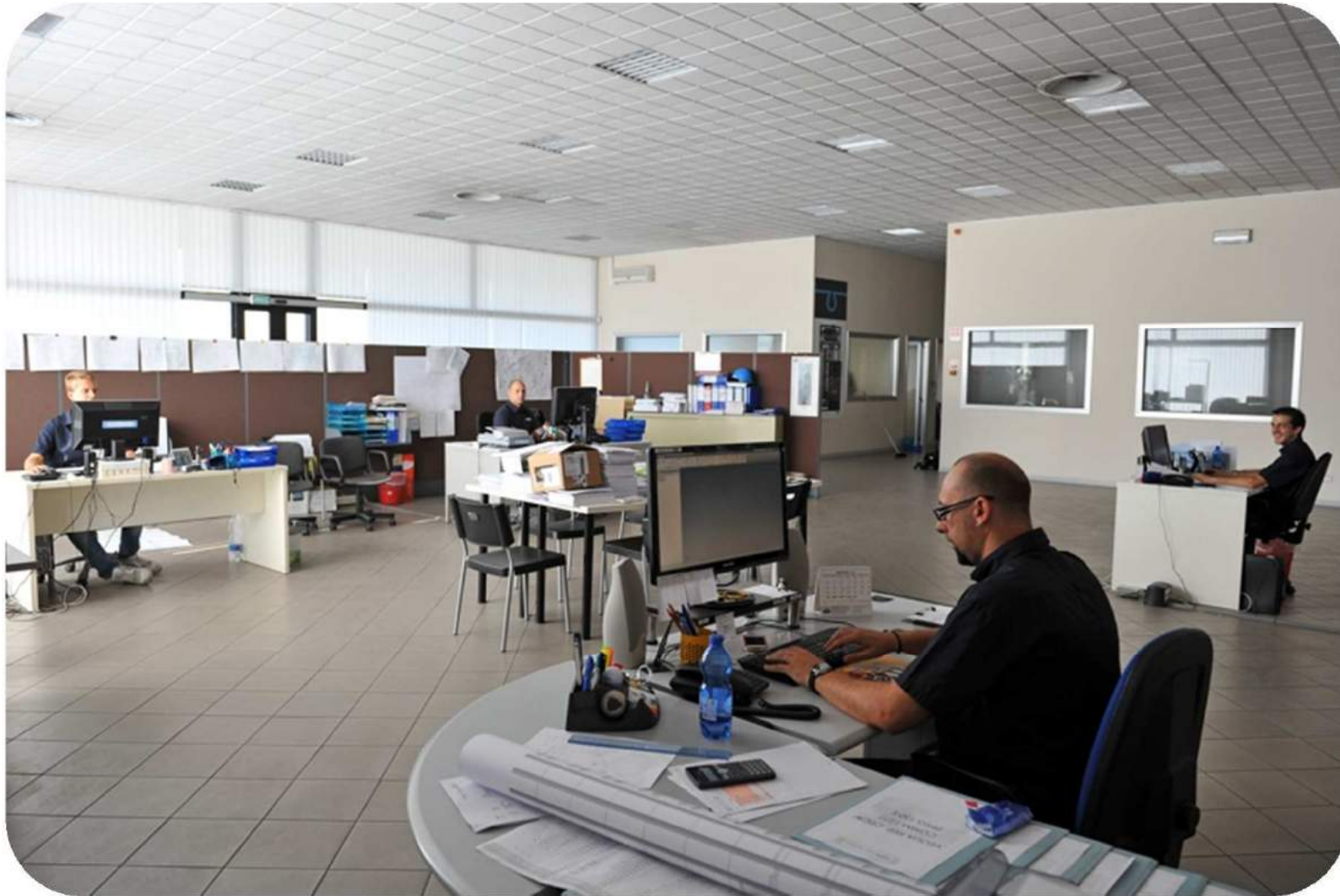



# OUR WORKSHOP

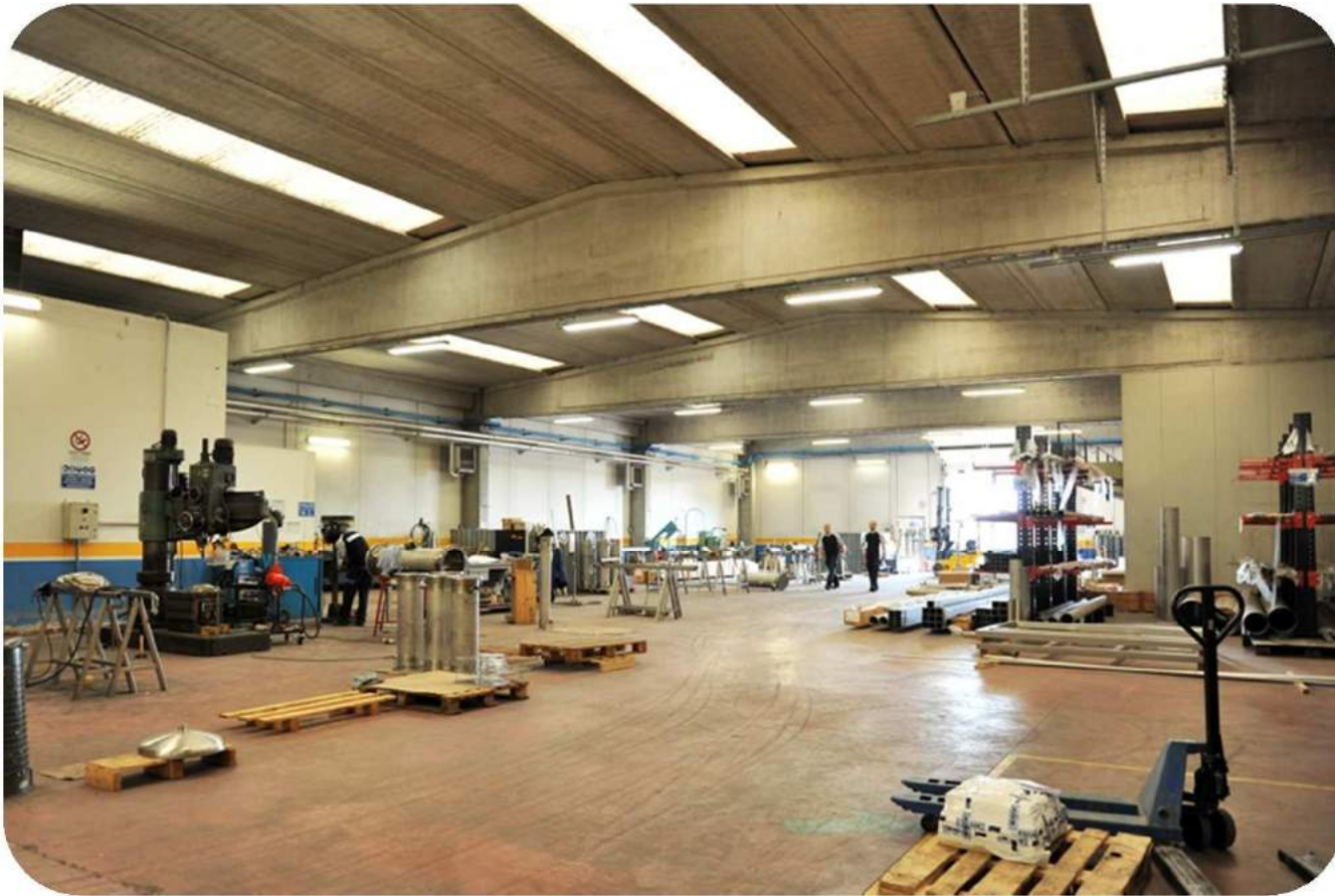





# EQUIPMENT

**PRIMARY WATER TREATMENTS**  
**MULTIMEDIA FILTERS**  
**SAND FILTERS**  
**ACTIVE CARBON FILTERS**  
**SOFTENERS**  
**CARTRIDGE MICROFILTRATION**  
**DOSING STATIONS FOR CHEMICAL SOLUTIONS**  
**WATER TREATMENT BY DEMINERALIZATORS AND REVERSE OSMOSIS PLANTS**  
**(TO PRODUCE SOFT WATER, POTABLE WATER AND SEA WATER)**  
**C.D.I.**  
**MULTIPLE EFFECT DISTILLERS**  
**THERMOCOMPRESSION DISTILLERS**  
**PURE STEAM GENERATORS**  
**MICROFILTRATION (ceramic and polymer)**  
**ULTRAFILTRATION (ceramic and polymer)**  
**NANOFILTRATION**  
**DIAFILTRATION**  
**PROCESS TECHNOLOGIES FOR THE RECOVERY OF PROTEINS IN DAIRY PRODUCTS**  
**STORAGE TANKS**  
**MIXING TANKS**  
**DISTRIBUTION LOOPS**  
**CIP/SIP SYSTEMS**  
**EXCHANGERS**  
**OZONE GENERATORS AND OZONE METERS**  
**TURBO EMULSIFIERS**  
**DUST LOAD SYSTEMS**

# GDN Pharma Line





# GDN Pharma Line



# GDN Pharma Line



SW	GDN Water Treatment	BW
PW		WFI

# GDN Pharma Line



# **LAB DISTILLER**



**VERY SIMPLE DESIGN**

**FED BY ANY KIND OF WATER**

**LOW CONSUMPTION  
LOW MANTAINANCE COSTS  
NO COOLING WATER**

**WFI FLOW 50 It/hr**

**COLD DISTILLED WATER  
PRODUCTION**

**GREAT QUALITY/PRICE  
RELATIONSHIP**

**LONG LIFE**











# GDN Industrial Line



**Our main goal:**

**ANSWER TO ALL OUR CUSTOMERS  
NEEDS IN TERMS OF**

**TECHNOLOGY-QUALITY-MAXIMUM  
FLEXIBILITY AND, ABOVE ALL,  
COST EFFECTIVE SOLUTIONS**

# *GDN unique selling advantages*

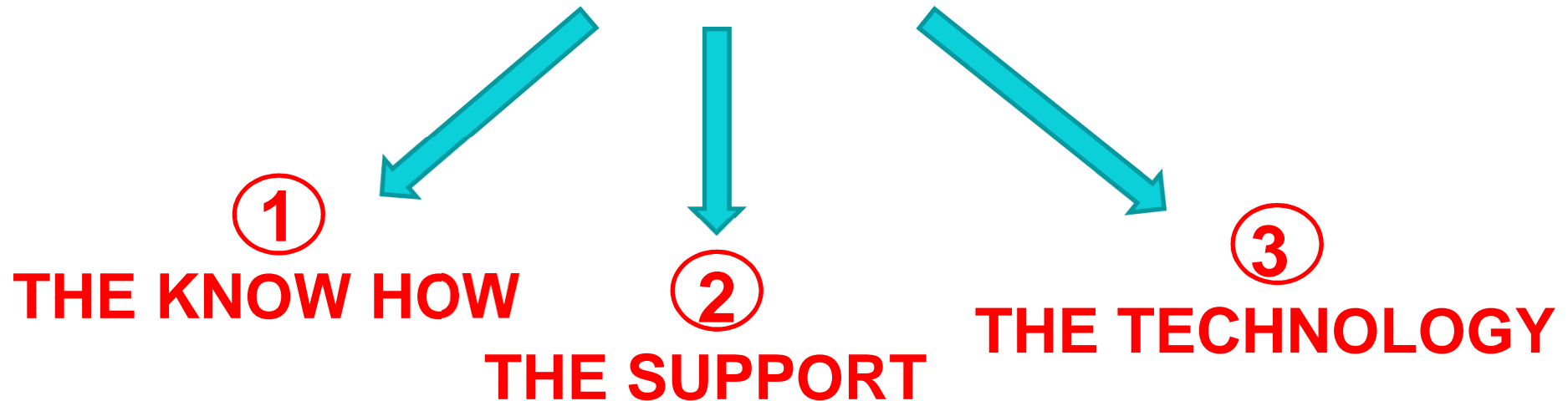

1) 40 years of experience from **PONZINI** to **GDN**

2) Complete **CUSTOMERIZATION**

3) **HIGH TECH** solutions and equipments



# *1) Know How*

- **1972** Giovanni Solzi, the owner of GDN, at the age of 22, is part of the Ponzini staff and starts his long career in the design, manufacture of thermocompression distillers
- **1989** Giovanni Solzi becomes the Technical Manager of Ponzini
- **2007** Giovanni Solzi becomes the Technical Manager of the multinational company Veolia Water
- **2009** Veolia Water in Soresina closes due to the severe global financial crisis and Giovanni Solzi, at the age of 59, decides to start his own company taking over from Veolia the tools, the materials and all the employees.



**In 44 years of experience  
Giovanni Solzi can pride  
himself on having witnessed  
the birth and the operation of at  
least 3000 distillers.**



## **OUR BEST EQUIPMENT**

**Thermocompression distiller**

**The result of 42 years of research and  
development of an incomparable high  
technology**



## *2) Complete Customization*



# We can do it all:

- **Temperature and flows**
- **Dimensions**
- **Special treatments**

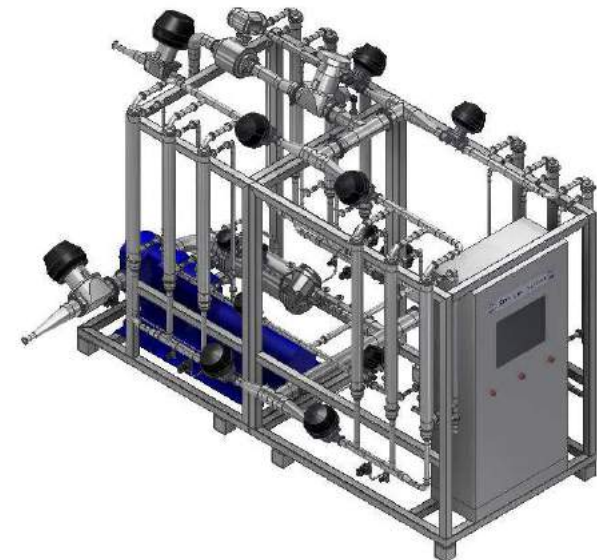

# 3) High Tech solutions and equipment

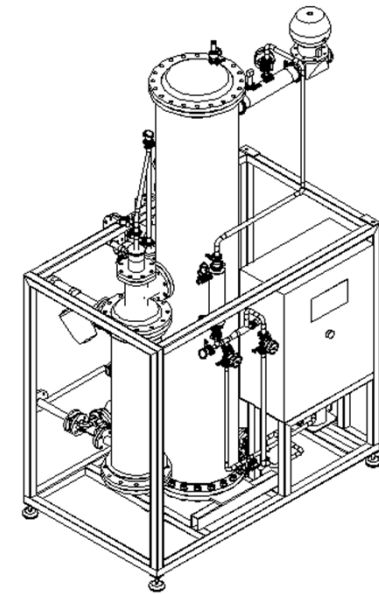
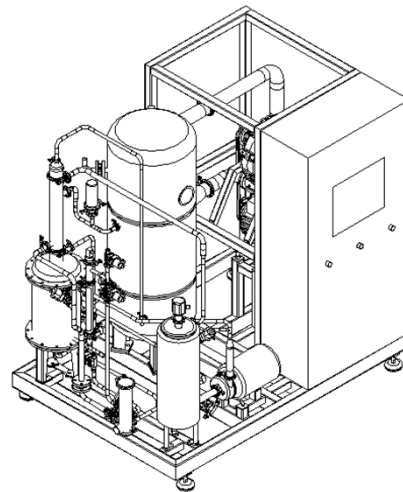
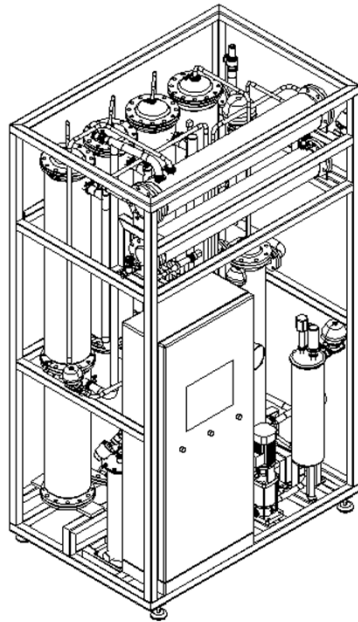

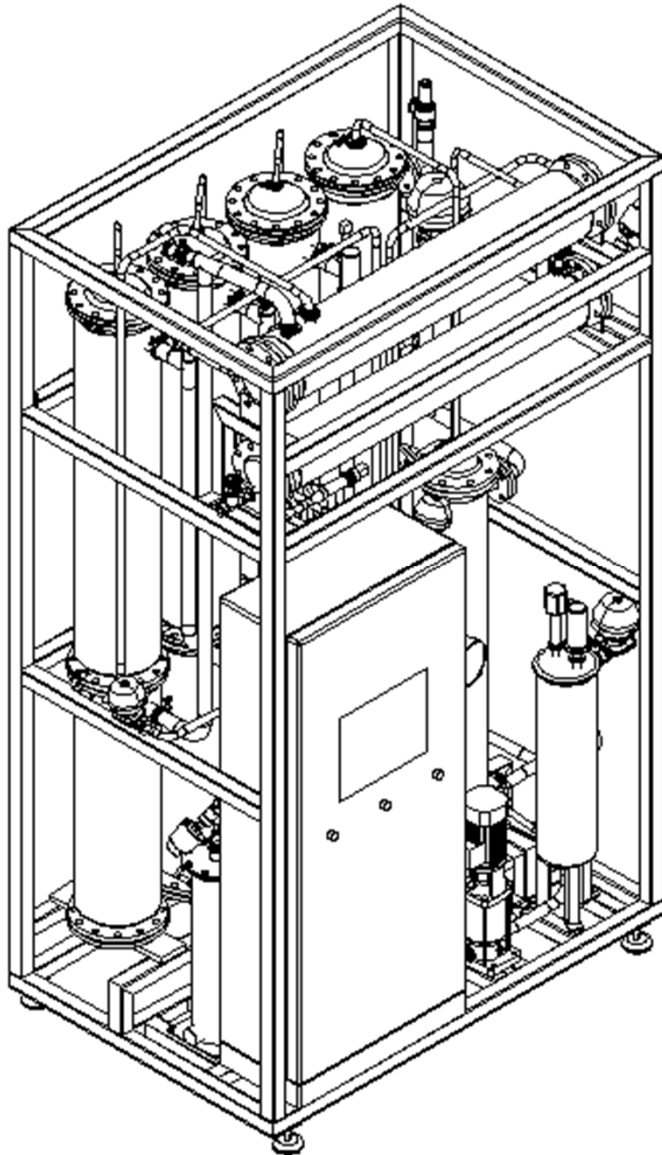

# PSME HIGH TECH

- 1. Falling film**  
High tech level
- 2. No dead legs**  
Sanitary equipments

# PSMC HIGH TECH

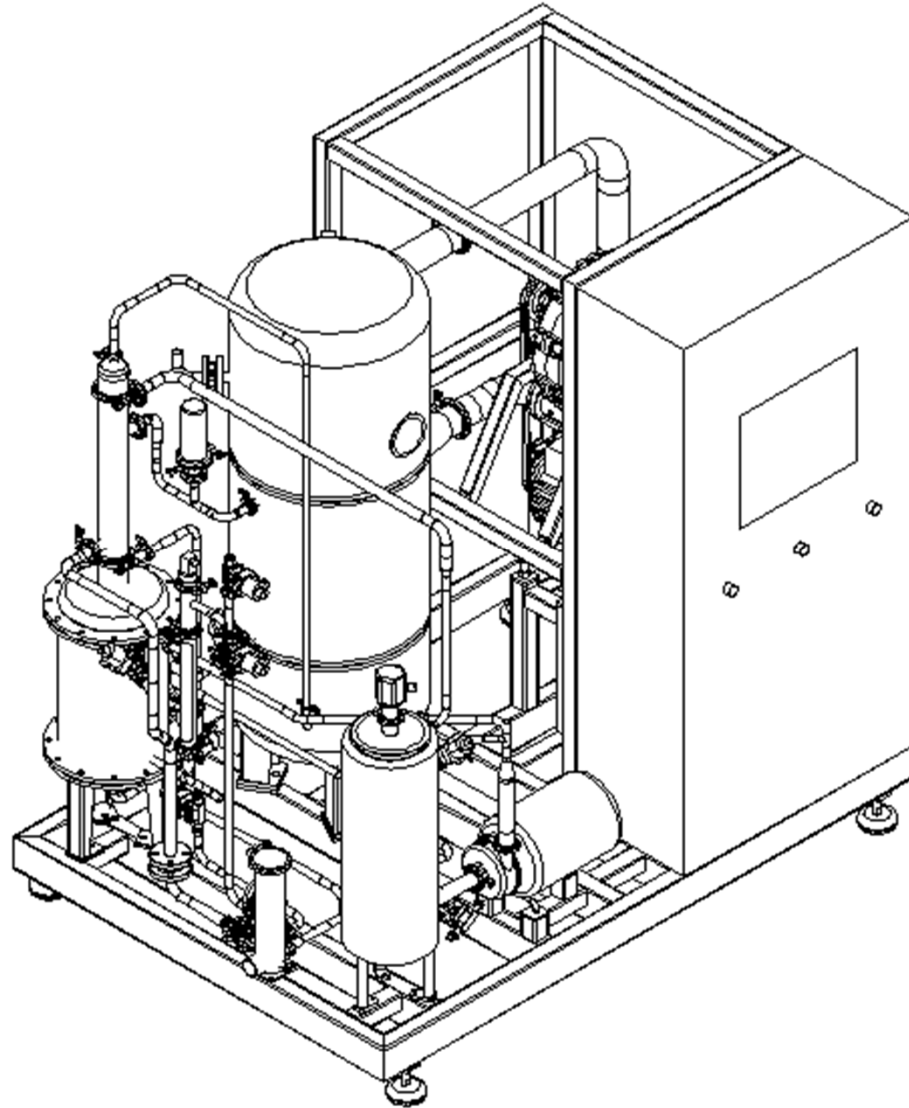

1. **Blower vs volumetric compressor**
2. **Three different degassing systems**
3. **Always changing and adapting**

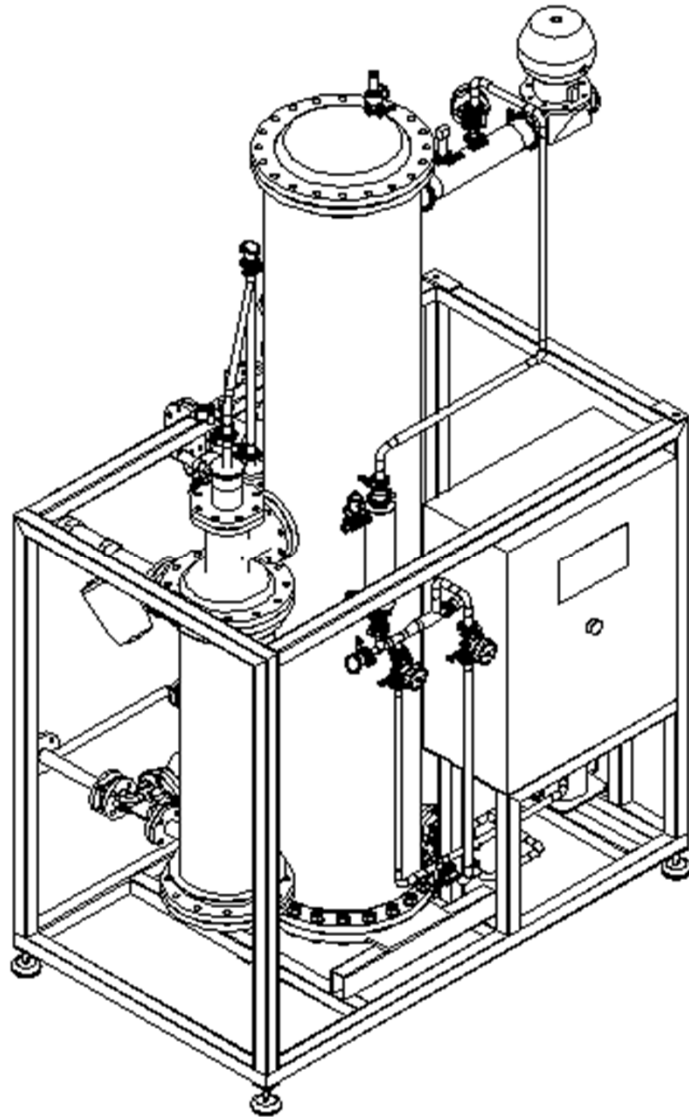

# PPSG HIGH TECH

Special degassing  
systems:

- Preheater
- Thermosyphon

Anti-pollution system

EN 285 conformity



# **WORKING PHILOSOPHY:**

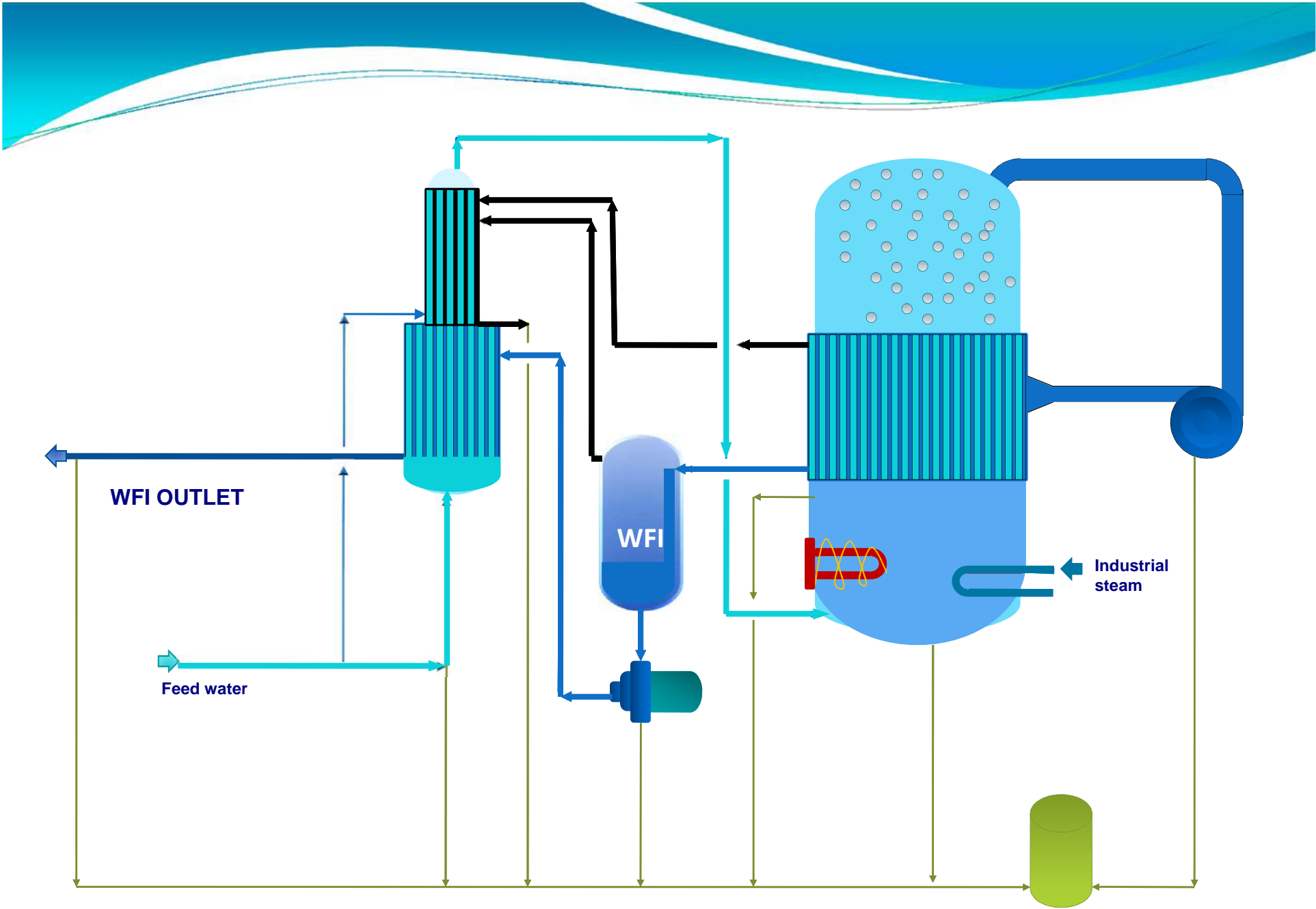

PSMC





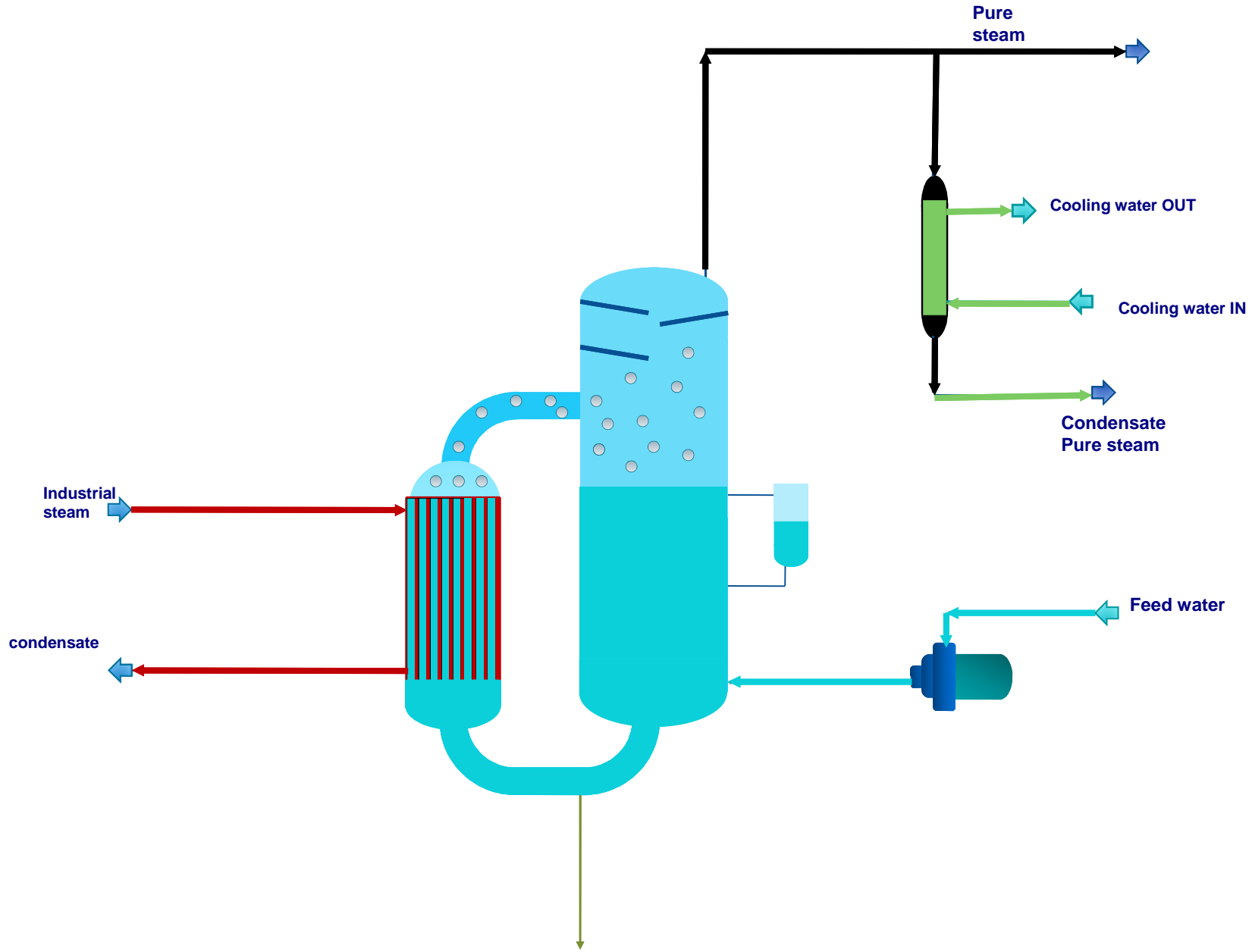

## Several models: From limited productions (100 l/h)...



...to bigger productions (15.000 l/h and more)



**Our main goal:**

**GIVE AN ANSWER TO ALL OF OUR  
CUSTOMER'S NEEDS IN TERMS OF  
  
TECHNOLOGY- QUALITY –  
MAXIMUM FLEXIBILITY AND ABOVE  
ALL SAVING MONEY**

# AND ALSO:

**Industrial PC and SCADA as standard**

**SS AISI 304 control board as standard**

**SS AISI 304 skid as standard**

**Only sanitary membrane valves are used**

**Only TC ASME BPE connections are used**

**First choice components: GEMU, SIEMENS,  
ENDRESS + HAUSER, WIKA, GRUNDFOS**

# Our standard control board in INOX and with standard SCADA



SW GDN Water Treatment BW  
PW WFI

# Dedicated SCADA

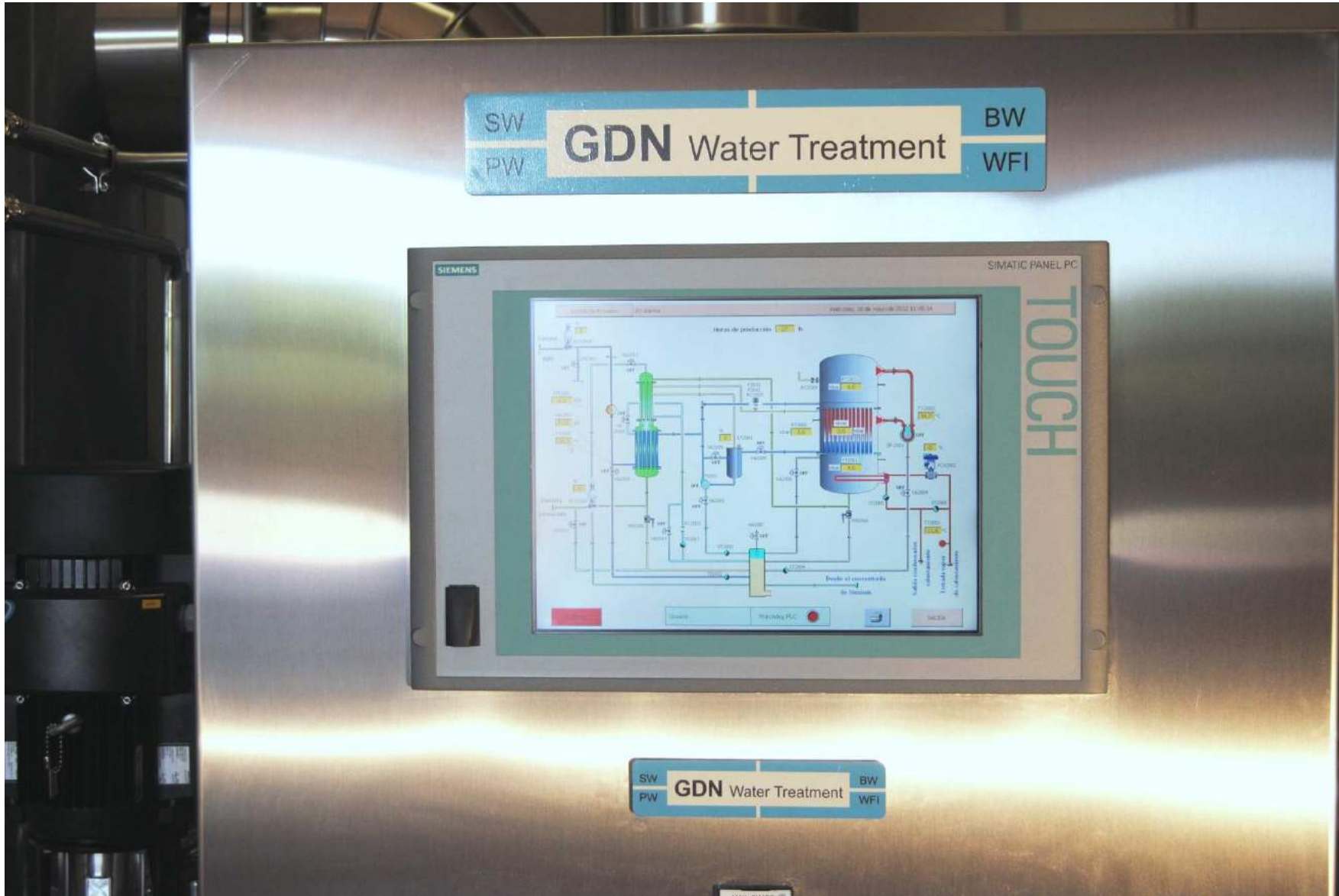

# Dedicated SCADA

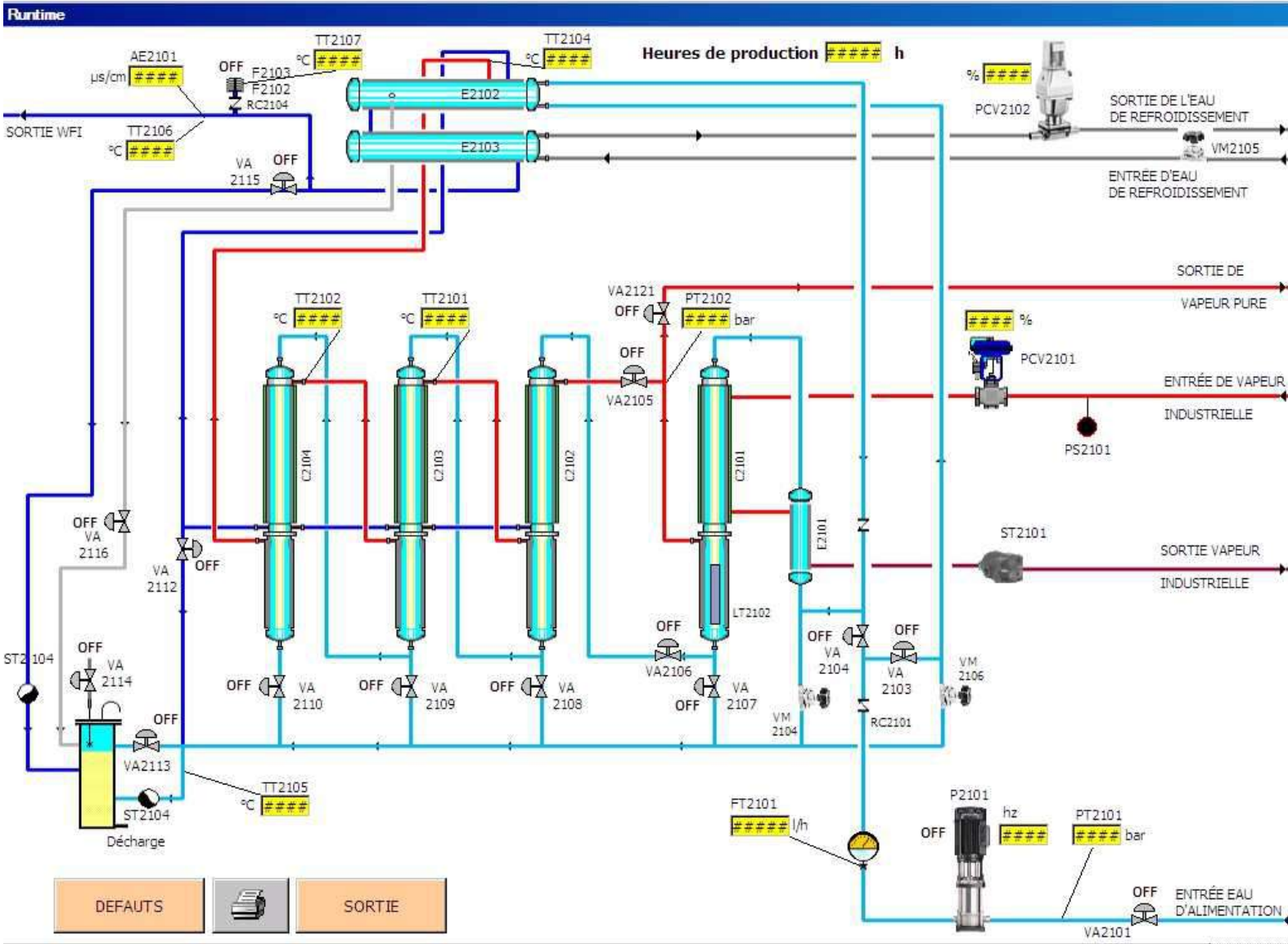



SW  
PW

**GDN** Water Treatment

BW  
WFI

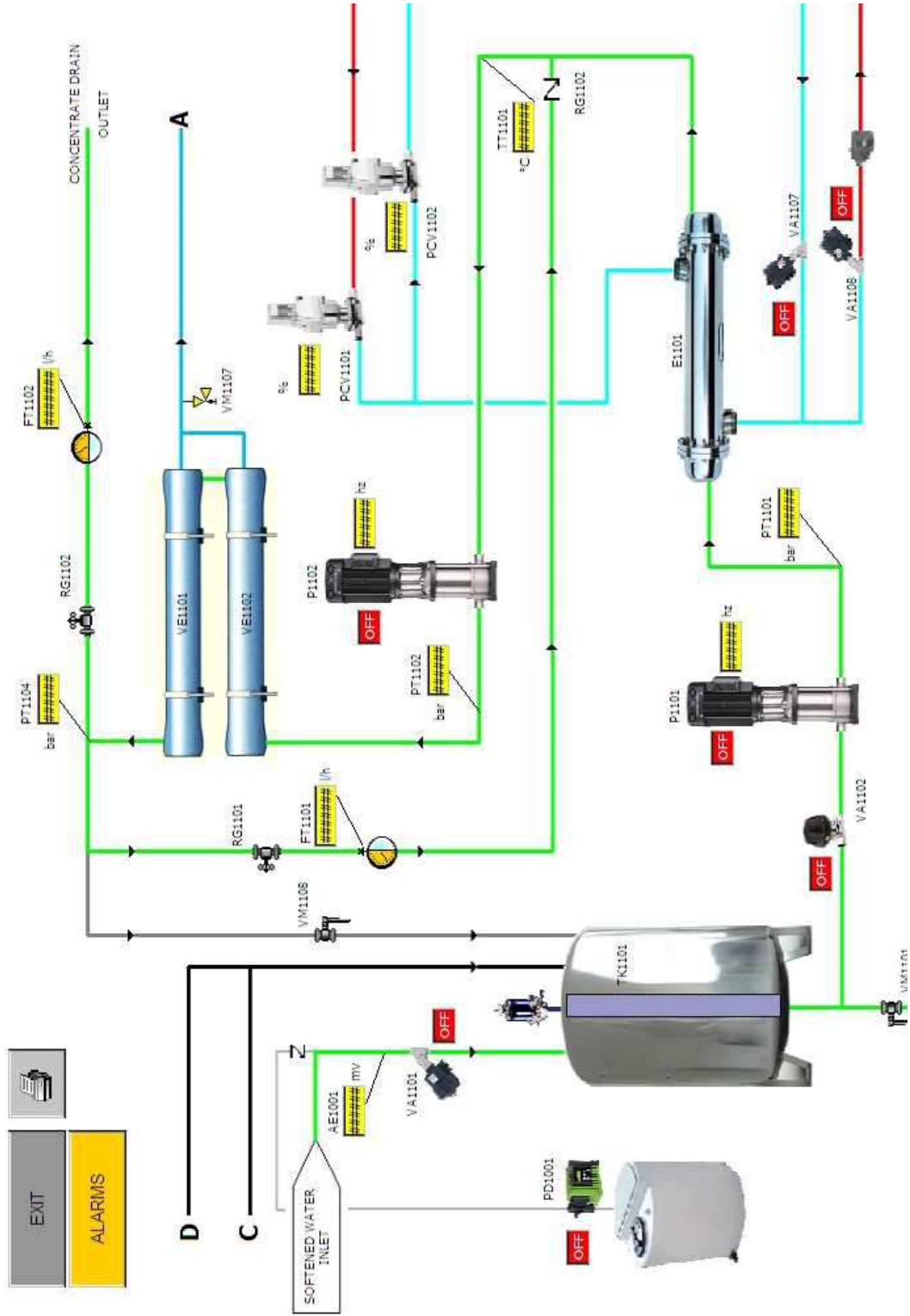

EXIT

ALARMS



# HIGH TECH COMPONENTS

- **All the components are made in Italy/Europe**
- **All the components are last generation, high tech and high quality items**
- **Our suppliers are only first choice suppliers**
- **Our service and spare parts are always available**



SEVENTY #SEVEN

Officina e distribuzione servizi



**MACADDA MANIA**  
**VIVIDIVIVA**  
Underlining Performance



Endress+Hauser

**BARDIANI**  
VALVOLE



Azienda • Prodotti • Produzione • Contatti



Le Termoidraulico



**D-ECKWEILER**  
ROHRSYSTEME AUS EDELSTAHL

**spirax/sarco**



**F.LLI TASSALINI s.p.a.**



**GRUNDFOS**

**PURO s.r.l.**  
Water Technology

telmotor



ELETTROFORNITURE



**SIEMENS**



**Roffia**



**POLYSOUDE**



Power Equipments



divisione PEERS

# VALIDATION

All the welders, the welding operators, the welding activities and the WPS (welding procedure specification) are qualified and certified according to these rules:

- ASME BPE 2002
- UNI EN 15614-1
- UNI EN 729-2
- UNI EN 287-1
- UNI EN ISO 6947 :1998
- UNI EN 719 :1996
- UNI EN ISO 14554-1 :2001
- UNI EN 1418 :1999

- 92/31 CEE
- 93/68 CEE and what foreseen by the harmonized International norms for low tension
- 73/22 CEE
  
- D.P.R. 459 24/07/1996
- Legislative Decree 476 04/12/1992

# DOCUMENTATION

- **cGMP**
- **F.D.A. rules**
- **ISPE baseline**
- **USP 37/ NF 32**
- **European Pharmacopeia 7th edition**
- **ASME BPE**
- **PED**
  
- **CFR21**
- **GAMP 5**
- **EN 285 conformity**
- **CE conformity declaration**
  
- **DQ/IQ/OQ/PQ**
- **Operating and maintenance manuals**
- **Customized documentation**
- **Customized drawings**

START UP  
COMMISSIONING  
TRAINING  
IQ/OQ EXECUTION  
INSTRUMENTS RECALIBRATION  
24/7 AFTERSALES SERVICE



# ON-SITE AND OFF-SITE PLANNED MAINTENANCE ACTIVITIES

