

Charles M. Lizza  
William C. Baton  
Sarah A. Sullivan  
SAUL EWING ARNSTEIN & LEHR LLP  
One Riverfront Plaza  
1037 Raymond Blvd., Suite 1520  
Newark, NJ 07102-5426  
(973) 286-6700  
clizza@saul.com

*Attorneys for Plaintiffs*  
*Boehringer Ingelheim Pharmaceuticals, Inc.,*  
*Boehringer Ingelheim International GmbH,*  
*and* *Boehringer Ingelheim Pharma GmbH &*  
*Co. KG*

*OF COUNSEL:*

Christopher N. Sipes  
R. Jason Fowler  
Jeremy D. Cobb  
COVINGTON & BURLING LLP  
One CityCenter  
850 Tenth Street NW  
Washington, DC 20001-4956  
Tel: (202) 662-6000

**UNITED STATES DISTRICT COURT  
DISTRICT OF NEW JERSEY**

BOEHRINGER INGELHEIM  
PHARMACEUTICALS, INC.,  
BOEHRINGER INGELHEIM  
INTERNATIONAL GMBH, and  
BOEHRINGER INGELHEIM PHARMA  
GMBH & CO. KG,

Plaintiffs,

v.

LUPIN ATLANTIS HOLDINGS SA and  
LUPIN LIMITED,

Defendants.

**Civil Action No.** \_\_\_\_\_

**(Filed Electronically)**

**COMPLAINT FOR PATENT INFRINGEMENT**

Plaintiffs *Boehringer Ingelheim Pharmaceuticals, Inc.,* *Boehringer Ingelheim International GmbH,* and *Boehringer Ingelheim Pharma GmbH & Co. KG* (collectively, “Plaintiffs” or “Boehringer Ingelheim”) by their undersigned attorneys, bring this action against

Lupin Atlantis Holdings SA and Lupin Limited (collectively, “Defendants” or “Lupin”), and hereby allege as follows:

### **NATURE OF THE ACTION**

1. This action for patent infringement, brought pursuant to the patent laws of the United States, 35 U.S.C. § 1, *et seq.*, and in particular under 35 U.S.C §§ 271 (a–c, e–g), arises from Lupin’s submission of Abbreviated New Drug Application (“ANDA”) No. 211287 to the United States Food and Drug Administration (“FDA”). Through this ANDA, Lupin seeks approval to market a generic version of the pharmaceutical product SPIRIVA® HandiHaler®, prior to the expiration of United States Patent Nos. 7,070,800 and 7,694,676 (the “patents-in-suit”). Plaintiffs seek injunctive relief precluding infringement, attorneys’ fees, and any other relief the Court deems just and proper.

2. This is also an action under 28 U.S.C. §§ 2201–02 for a declaratory judgment of patent infringement arising under the patent laws of the United States, 35 U.S.C. §§ 1, *et seq.*, and in particular under 35 U.S.C. § 271.

### **THE PARTIES**

3. Plaintiff Boehringer Ingelheim Pharmaceuticals, Inc. is a corporation organized and existing under the laws of the State of Delaware, having a principal place of business at 900 Ridgebury Road, Ridgefield, Connecticut 06877.

4. Plaintiff Boehringer Ingelheim International GmbH is a private limited liability company organized and existing under the laws of Germany, having a principal place of business at Binger Strasse 173, 55216 Ingelheim, Germany.

5. Plaintiff Boehringer Ingelheim Pharma GmbH & Co. KG is a corporation organized and existing under the laws of Germany, having a principal place of business at Binger Str. 173, 55216 Ingelheim, Germany.

6. On information and belief, defendant Lupin Atlantis Holdings SA is a corporation organized and existing under the laws of Switzerland, having its principal place of business at Landis & Gyr-Strasse 1, Zug, Switzerland 6300.

7. On information and belief, defendant Lupin Limited is a corporation organized and existing under the laws of India, having its principal place of business at Laxmi Towers, 'B' Wing, 5th Floor, Bandra Kurla Complex, Bandra (East), Mumbai, India 40051.

8. On information and belief, Lupin Atlantis Holdings SA is a wholly owned subsidiary of Lupin Limited.

9. On information and belief, Lupin Atlantis Holdings SA, in collaboration with Lupin Limited, prepared and submitted ANDA No. 211287 (the "Lupin ANDA") and continues to collaborate in seeking FDA approval of that application.

10. On information and belief, Lupin intends to commercially manufacture, market, offer for sale, and sell the product described in the Lupin ANDA (the "ANDA Product") throughout the United States, including in the State of New Jersey, in the event FDA approves the Lupin ANDA.

### **JURISDICTION AND VENUE**

11. This civil action for patent infringement arises under the patent laws of the United States, including 35 U.S.C. § 271, and alleges infringement of United States Patent Nos. 7,070,800 ("the '800 patent") and 7,694,676 ("the '676 patent"). This Court has jurisdiction over the subject matter of this action pursuant to 28 U.S.C. §§ 1331, 1338, and 2201–02.

12. This Court has jurisdiction over Lupin because the requirements of Federal Rule of Civil Procedure 4(k)(2) are met as (a) Plaintiffs' claims arise under federal law; (b) Lupin Atlantis Holdings SA and Lupin Limited are foreign defendants not subject to general personal jurisdiction in the courts of any state; and (c) Lupin Atlantis Holdings SA and Lupin Limited have sufficient contacts with the United States as a whole, including, but not limited to, preparing and submitting ANDAs to FDA and/or manufacturing, importing, offering to sell, and/or selling pharmaceutical products that are distributed throughout the United States, such that this Court's exercise of jurisdiction over Lupin Atlantis Holdings SA and Lupin Limited satisfies due process.

13. On information and belief, this Court also has jurisdiction over Lupin because, *inter alia*, this action arises from actions of Lupin directed toward New Jersey and because Lupin has purposefully availed itself of the rights and benefits of New Jersey law by engaging in systematic and continuous contacts with New Jersey.

14. On information and belief, Lupin regularly and continuously transacts business within the State of New Jersey, including by selling pharmaceutical products in New Jersey, either on its own or through an affiliate. Upon information and belief, Lupin derives substantial revenue from the sale of those products in New Jersey and has availed itself of the privilege of conducting business within the State of New Jersey. Further, Lupin has committed, or aided, abetted, contributed to, and/or participated in the commission of, acts of patent infringement that will lead to foreseeable harm and injury to Plaintiffs, which manufactures SPIRIVA® HandiHaler® for sale and use throughout the United States, including this Judicial District.

15. On information and belief, Lupin Atlantis Holdings SA has submitted, caused to be submitted, or aided and abetted in the preparation or submission of the Lupin ANDA. On

information and belief, in the event that FDA approves the Lupin ANDA, Lupin Atlantis Holdings SA, with the participation of Lupin Limited, intends to commercially manufacture, import, market, offer for sale, and sell the ANDA Product throughout the United States and in this Judicial District.

16. Lupin has previously been sued in this Judicial District without objecting on the basis of lack of personal jurisdiction and has availed itself of the rights, benefits, and privileges of New Jersey by asserting claims or counterclaims involving pharmaceutical drug patent disputes in this Judicial District, including in the following cases: *Otsuka Pharmaceutical Co. Ltd. v. Lupin Limited, et al.*, Civil Action No. 14-7105; *Taro Pharmaceuticals USA, Inc. et al. v. Lupin Limited, et al.*, Civil Action No. 18-4228.

17. At least because, on information and belief, Lupin is a foreign corporation, venue is proper in this Judicial District pursuant to 28 U.S.C. §§ 1391(c)(3) and 1400(b).

**BOEHRINGER INGELHEIM'S APPROVED SPIRIVA® DRUG PRODUCT  
AND PATENTS-IN-SUIT**

18. Boehringer Ingelheim makes and sells SPIRIVA® HandiHaler®, a product that is used as an anticholinergic indicated for the long-term, once-daily, maintenance treatment of bronchospasm associated with chronic obstructive pulmonary disease (COPD), and for reducing COPD exacerbations. A true and correct copy of the prescribing label for SPIRIVA® HandiHaler® is attached as Exhibit A.

19. Boehringer Ingelheim Pharmaceuticals, Inc. is the holder of New Drug Application (“NDA”) No. 021395 for SPIRIVA® HandiHaler® and the licensee of the patents-in-suit. FDA approved NDA No. 021395 for SPIRIVA® HandiHaler® in January 2004.

20. Boehringer Ingelheim Pharma GmbH & Co. KG owns the '800 patent, which is listed in the Approved Drug Products With Therapeutic Equivalence Evaluations (an FDA publication commonly known as the "Orange Book") for SPIRIVA® HandiHaler®.

21. The '800 patent is entitled, "Inhalable Powder Containing Tiotropium," and was duly and lawfully issued by the USPTO on July 4, 2006. A true and correct copy of the '800 patent is attached as Exhibit B.

22. Boehringer Ingelheim International GmbH owns the '676 patent, which is listed in the Orange Book for SPIRIVA® HandiHaler®.

23. The '676 patent is entitled, "Dry Powder Inhaler," and was duly and lawfully issued by the USPTO on April 13, 2010. A true and correct copy of the '676 patent is attached as Exhibit C.

#### **LUPIN'S ANDA**

24. On information and belief, Lupin has submitted or caused to be submitted ANDA No. 211287 to FDA under 21 U.S.C. § 355(j), in order to obtain approval to engage in the commercial manufacture, use, or sale of tiotropium bromide inhalation powder, 18 mcg/capsule, as a purported generic version of SPIRIVA® HandiHaler®, prior to the expiration of the patents-in-suit.

25. On information and belief, on or about June 26, 2018, Lupin mailed Plaintiffs a letter regarding "Notification of Certification" of Invalidity, Unenforceability, and/or Non-Infringement for U.S. Patent Nos. 7,070,800 B2 and 7,694,676 B2, (the "Notice Letter"). The Notice Letter represented that Lupin had submitted to FDA the Lupin ANDA and a purported Paragraph IV certification to obtain approval to engage in the commercial manufacture, use, or sale of the product described in the Lupin's ANDA before the expiration of

the '800 and '676 patents, which are listed in the Orange Book for SPIRIVA® HandiHaler®.

Hence, Lupin's purpose in submitting the Lupin ANDA is to manufacture and market the ANDA Product before the expiration of the patents-in-suit.

26. Lupin's Notice Letter stated that the Paragraph IV certification in the Lupin ANDA alleges that the '800 patent is invalid, unenforceable, and/or will not be infringed by the commercial manufacture, use, or sale of the ANDA Product.

27. Lupin's Notice Letter stated that the Paragraph IV certification in the Lupin ANDA alleges that the '676 patent is invalid, unenforceable, and/or will not be infringed by the commercial manufacture, use, or sale of the ANDA Product.

28. Lupin's Notice Letter contained a purported detailed statement of the factual and legal basis for its Paragraph IV certification ("Detailed Statement").

29. Lupin has participated in the preparation and submission of the Lupin ANDA, has provided material support to the preparation and submission of the Lupin ANDA, and intends to support the further prosecution of the Lupin ANDA.

30. On information and belief, if FDA approves the Lupin ANDA, Lupin will manufacture, offer for sale, or sell the ANDA Product within the United States, including within New Jersey, or will import the ANDA Product into the United States, including New Jersey.

31. Alternatively, on information and belief, if FDA approves the Lupin ANDA, Lupin will actively induce or contribute to the manufacture, use, offer for sale, or sale of the ANDA Product within the United States, including within New Jersey, or will import the ANDA Product into the United States, including New Jersey.

32. This action is being filed on August 10, 2018, which is within forty-five days of Plaintiffs' receipt of the Notice Letter, pursuant to 21 U.S.C. § 355(j)(5)(B)(iii).

**COUNT I  
INFRINGEMENT OF THE '800 PATENT**

33. Plaintiffs incorporate by reference paragraphs 1–32 as if fully set forth herein.

34. On information and belief, Lupin has submitted or caused the submission of the Lupin ANDA to FDA and continues to seek FDA approval of the Lupin ANDA.

35. Lupin has infringed the '800 patent under 35 U.S.C. § 271(e)(2)(A) by submitting the Lupin ANDA with a Paragraph IV certification and seeking FDA approval of the Lupin ANDA prior to the expiration of the '800 patent.

36. On information and belief, if the Lupin ANDA is approved, Lupin and its affiliates will make, offer for sale, sell, import, or otherwise distribute the ANDA Product in the United States, including in the State of New Jersey, directly infringing the '800 patent.

37. Lupin's commercial manufacture, use, offer for sale, sale, or importation into the United States of the ANDA Product would actively induce and/or contribute to infringement of the '800 patent. Accordingly, unless enjoined by this Court, upon FDA approval of ANDA No. 211287, Lupin will make, use, offer to sell, or sell the ANDA Product within the United States, or will import the ANDA Product into the United States, and will thereby contribute to the infringement of and/or induce the infringement of one or more claims of the '800 patent.

38. Lupin had actual and constructive notice of the '800 patent prior to filing the Lupin ANDA and was aware that the filing of the Lupin ANDA with the request for FDA approval prior to the expiration of the '800 patent would constitute an act of infringement of the '800 patent. Lupin had no reasonable basis for asserting that the commercial manufacture, use, offer for sale, or sale of the ANDA Product will not directly infringe, contribute to the infringement of, and/or induce the infringement of the '800 patent.



39. In addition, Lupin filed the Lupin ANDA without adequate justification for asserting the '800 patent to be invalid, unenforceable, and/or not infringed by the commercial manufacture, use, offer for sale, or sale of the ANDA Product. Lupin's conduct in certifying invalidity, unenforceability, and/or non-infringement with respect to the '800 patent thus renders this case "exceptional" under 35 U.S.C. § 285.

40. Plaintiffs will be irreparably harmed if Lupin is not enjoined from infringing and from actively inducing or contributing to the infringement of the '800 patent. Plaintiffs do not have an adequate remedy at law, and considering the balance of hardships between Plaintiffs and Lupin, a remedy in equity is warranted. Further, the public interest would not be disserved by the entry of a permanent injunction.

**COUNT II  
INFRINGEMENT OF THE '676 PATENT**

41. Plaintiffs incorporate by reference paragraphs 1–40 as if fully set forth herein.

42. On information and belief, Lupin has submitted or caused the submission of the Lupin ANDA to FDA and continues to seek FDA approval of the Lupin ANDA.

43. Lupin has infringed the '676 patent under 35 U.S.C. § 271(e)(2)(A) by submitting the Lupin ANDA with a Paragraph IV certification and seeking FDA approval of the Lupin ANDA prior to the expiration of the '676 patent.

44. On information and belief, if the Lupin ANDA is approved, Lupin and its affiliates will make, offer for sale, sell, import, or otherwise distribute the ANDA Product in the United States, including in the State of New Jersey, directly infringing the '676 patent.

45. Lupin's commercial manufacture, use, offer for sale, sale, or importation into the United States of the ANDA Product would actively induce and/or contribute to infringement of the '676 patent. Accordingly, unless enjoined by this Court, upon FDA approval of ANDA No.

211287, Lupin will make, use, offer to sell, or sell the ANDA Product within the United States, or will import the ANDA Product into the United States, and will thereby contribute to the infringement of and/or induce the infringement of one or more claims of the '676 patent.

46. Lupin had actual and constructive notice of the '676 patent prior to filing the Lupin ANDA and was aware that the filing of the Lupin ANDA with the request for FDA approval prior to the expiration of the '676 patent would constitute an act of infringement of the '676 patent. Lupin had no reasonable basis for asserting that the commercial manufacture, use, offer for sale, or sale of the ANDA Product will not directly infringe, contribute to the infringement of, and/or induce the infringement of the '676 patent.

47. In addition, Lupin filed the Lupin ANDA without adequate justification for asserting the '676 patent to be invalid, unenforceable, and/or not infringed by the commercial manufacture, use, offer for sale, or sale of the ANDA Product. Lupin's conduct in certifying invalidity, unenforceability, and/or non-infringement with respect to the '676 patent renders this case "exceptional" under 35 U.S.C. § 285.

48. Plaintiffs will be irreparably harmed if Lupin is not enjoined from infringing and from actively inducing or contributing to the infringement of the '676 patent. Plaintiffs do not have an adequate remedy at law, and considering the balance of hardships between Plaintiffs and Lupin, a remedy in equity is warranted. Further, the public interest would not be disserved by the entry of a permanent injunction.

**COUNT III**  
**DECLARATORY JUDGMENT OF INFRINGEMENT OF THE '800 PATENT**

49. Plaintiffs incorporate by reference paragraphs 1–48 as if fully set forth herein.

50. Plaintiffs' claims also arise under the Declaratory Judgment Act, 28 U.S.C. §§ 2201 and 2202.

51. On information and belief, if the Lupin ANDA is approved, the ANDA Product will be made, offered for sale, sold, or otherwise distributed in the United States, including in the State of New Jersey, by or through Lupin and its affiliates.

52. On information and belief, Lupin knows that health care professionals or patients will use the ANDA Product in accordance with the labeling sought by the Lupin ANDA and Lupin will therefore contribute to the infringement of and/or induce the infringement of one or more claims of the '800 patent under one or more of 35 U.S.C. §§ 271(a), (b), (c), (f), and (g).

53. On information and belief, Lupin's infringing activity, including the commercial manufacture, use, offer to sell, sale, or importation of the ANDA Product complained of herein will begin immediately after FDA approves the Lupin ANDA. Any such conduct before the '800 patent expires will contribute to the infringement of and/or induce the infringement of one or more claims of the '800 patent under one or more of 35 U.S.C. §§ 271(a), (b), (c), (f), and (g).

54. As a result of the foregoing facts, there is a real, substantial, and continuing justiciable controversy between Plaintiffs and Lupin concerning liability for the infringement of the '800 patent for which this Court may grant declaratory relief consistent with Article III of the United States Constitution.

55. Plaintiffs will be substantially and irreparably harmed by Lupin's infringing activities unless those activities are enjoined by this Court. Plaintiffs have no adequate remedy at law.

56. This case is exceptional, and Plaintiffs are entitled to an award of attorneys' fees under 35 U.S.C. § 285.

**COUNT IV**  
**DECLARATORY JUDGMENT OF INFRINGEMENT OF THE '676 PATENT**

57. Plaintiffs incorporate by reference paragraphs 1–56 as if fully set forth herein.

58. Plaintiffs' claims also arise under the Declaratory Judgment Act, 28 U.S.C. §§ 2201 and 2202.

59. On information and belief, if the Lupin ANDA is approved, the ANDA Product will be made, offered for sale, sold, or otherwise distributed in the United States, including in the State of New Jersey, by or through Lupin and its affiliates.

60. On information and belief, Lupin knows that health care professionals or patients will use the ANDA Product in accordance with the labeling sought by the Lupin ANDA and Lupin will therefore contribute to the infringement of and/or induce the infringement of one or more claims of the '676 patent under one or more of 35 U.S.C. §§ 271(a), (b), (c), (f), and (g).

61. On information and belief, Lupin's infringing activity, including the commercial manufacture, use, offer to sell, sale, or importation of the ANDA Product complained of herein will begin immediately after FDA approves the Lupin ANDA. Any such conduct before the '676 patent expires will contribute to the infringement of and/or induce the infringement of one or more claims of the '676 patent under one or more of 35 U.S.C. §§ 271(a), (b), (c), (f), and (g).

62. As a result of the foregoing facts, there is a real, substantial, and continuing justiciable controversy between Plaintiffs and Lupin concerning liability for the infringement of the '676 patent for which this Court may grant declaratory relief consistent with Article III of the United States Constitution.

63. Plaintiffs will be substantially and irreparably harmed by Lupin's infringing activities unless those activities are enjoined by this Court. Plaintiffs have no adequate remedy at law.

64. This case is exceptional, and Plaintiffs are entitled to an award of attorneys' fees under 35 U.S.C. § 285.

### **PRAYER FOR RELIEF**

WHEREFORE, Plaintiffs respectfully request the following relief:

A. A Judgment that Lupin infringes one or more claims of the '800 patent and the '676 patent under 35 U.S.C. § 271(e)(2)(A);

B. A Declaratory Judgment that under one or more of 35 U.S.C. §§ 271(a), (b), (c), (f) and (g), Lupin's commercial manufacture, use, offer for sale, or sale in, or importation into, the United States of the ANDA Product, or inducing or contributing to such conduct, would constitute infringement of one or more claims of the '800 patent and '676 patent;

C. A permanent injunction, pursuant to 35 U.S.C. § 271(e)(4)(B), restraining and enjoining Lupin, its affiliates and subsidiaries, and all persons and entities acting in concert with Lupin from commercially manufacturing, using, offering for sale, or selling or importing any product that infringes the '800 patent and '676 patent, including the ANDA Product described in ANDA No. 211287;

D. The entry of an Order, pursuant to 35 U.S.C. § 271(e)(4)(A), that the effective date of any FDA approval of ANDA No. 211287 shall be no earlier than the expiration date of the '800 patent and '676 patent, or any later expiration of exclusivity for the '800 patent and '676 patent, including any extensions or regulatory exclusivities;

E. A Declaration under 28 U.S.C. § 2201 that if Lupin, its officers, agents, servants, employees, licensees, representatives, and attorneys, and any other persons acting or attempting to act in active concert or participation with them or acting on their behalf, engages in the commercial manufacture, use, offer for sale, sale and/or importation of the product described in

ANDA No. 211287, it will constitute an act of direct and/or indirect infringement of the '800 patent and '676 patent;

F. An award of damages or other relief, pursuant to 35 U.S.C. § 271(e)(4)(C), if Lupin engages in the commercial manufacture, use, offer for sale, sale, and/or importation of the ANDA Product, or any product that infringes the '800 patent and the '676 patent, or induces or contributes to such conduct, prior to the expiration of the '800 patent and the '676 patent, or any later expiration of exclusivity for the '800 patent and '676 patent, including any extensions or regulatory exclusivities;

G. The entry of Judgment declaring that Lupin's acts render this case an exceptional case, and awarding Plaintiffs their attorneys' fees pursuant to 35 U.S.C. §§ 271(e)(4) and 285;

H. An award to Plaintiffs of their costs and expenses in this action; and

I. Such other and further relief as the Court may deem just and proper.

Dated: August 10, 2018

*OF COUNSEL:*

Christopher N. Sipes  
R. Jason Fowler  
Jeremy D. Cobb  
COVINGTON & BURLING LLP  
One CityCenter  
850 Tenth Street, NW  
Washington, DC 20001  
(202) 662-6000

By: s/ Charles M. Lizza

Charles M. Lizza  
William C. Baton  
Sarah A. Sullivan  
SAUL EWING ARNSTEIN & LEHR LLP  
One Riverfront Plaza, Suite 1520  
Newark, NJ 07102-5246  
(973) 286-6700  
clizza@saul.com

*Attorneys for Plaintiffs  
Boehringer Ingelheim Pharmaceuticals,  
Inc., Boehringer Ingelheim International  
GmbH, and Boehringer Ingelheim Pharma  
GmbH & Co. KG*

**CERTIFICATION PURSUANT TO LOCAL CIVIL RULES 11.2 & 40.1**

I hereby certify that, to the best of my knowledge, the matter in controversy is not the subject of any action pending in any court or of any pending arbitration or administrative proceeding.

Dated: August 10, 2018

*OF COUNSEL:*

Christopher N. Sipes  
R. Jason Fowler  
Jeremy D. Cobb  
COVINGTON & BURLING LLP  
One CityCenter  
850 Tenth Street, NW  
Washington, DC 20001  
(202) 662-6000

By: s/ Charles M. Lizza  
Charles M. Lizza  
William C. Baton  
Sarah A. Sullivan  
SAUL EWING ARNSTEIN & LEHR LLP  
One Riverfront Plaza, Suite 1520  
Newark, NJ 07102-5246  
(973) 286-6700  
clizza@saul.com

*Attorneys for Plaintiffs  
Boehringer Ingelheim Pharmaceuticals,  
Inc., Boehringer Ingelheim International  
GmbH, and Boehringer Ingelheim Pharma  
GmbH & Co. KG*

# **EXHIBIT A**



**HIGHLIGHTS OF PRESCRIBING INFORMATION**

These highlights do not include all the information needed to use SPIRIVA HANDIHALER safely and effectively. See full prescribing information for SPIRIVA HANDIHALER.

**SPIRIVA® HANDIHALER® (tiotropium bromide inhalation powder), for oral inhalation use**  
Initial U.S. Approval: 2004

-----**INDICATIONS AND USAGE**-----

SPIRIVA HANDIHALER is an anticholinergic indicated for the long-term, once-daily, maintenance treatment of bronchospasm associated with chronic obstructive pulmonary disease (COPD), and for reducing COPD exacerbations (1)

-----**DOSAGE AND ADMINISTRATION**-----

- **For oral inhalation only. DO NOT swallow SPIRIVA capsules. Only use SPIRIVA capsules with the HANDIHALER device (2)**
- Two inhalations of the powder contents of a single SPIRIVA capsule (18 mcg) once daily (2)

-----**DOSAGE FORMS AND STRENGTHS**-----

Inhalation powder: SPIRIVA capsules contain 18 mcg tiotropium powder for use with HANDIHALER device (3)

-----**CONTRAINDICATIONS**-----

Hypersensitivity to tiotropium, ipratropium, or any components of SPIRIVA capsules (4)

-----**WARNINGS AND PRECAUTIONS**-----

- Not for acute use: Not a rescue medication (5.1)
- Immediate hypersensitivity reactions: Discontinue SPIRIVA HANDIHALER at once and consider alternatives if immediate hypersensitivity reactions, including angioedema, urticaria, rash,

bronchospasm, or anaphylaxis, occur. Use with caution in patients with severe hypersensitivity to milk proteins. (5.2)

- Paradoxical bronchospasm: Discontinue SPIRIVA HANDIHALER and consider other treatments if paradoxical bronchospasm occurs (5.3)
- Worsening of narrow-angle glaucoma may occur. Use with caution in patients with narrow-angle glaucoma and instruct patients to consult a physician immediately if this occurs. (5.4)
- Worsening of urinary retention may occur. Use with caution in patients with prostatic hyperplasia or bladder-neck obstruction and instruct patients to consult a physician immediately if this occurs. (5.5)

-----**ADVERSE REACTIONS**-----

The most common adverse reactions (>5% incidence in the 1-year placebo-controlled trials) were upper respiratory tract infection, dry mouth, sinusitis, pharyngitis, non-specific chest pain, urinary tract infection, dyspepsia, and rhinitis (6.1)

**To report SUSPECTED ADVERSE REACTIONS, contact Boehringer Ingelheim Pharmaceuticals, Inc. at (800) 542-6257 or (800) 459-9906 TTY, or FDA at 1-800-FDA-1088 or [www.fda.gov/medwatch](http://www.fda.gov/medwatch).**

-----**DRUG INTERACTIONS**-----

Anticholinergics: May interact additively with concomitantly used anticholinergic medications. Avoid administration of SPIRIVA HANDIHALER with other anticholinergic-containing drugs. (7.2)

-----**USE IN SPECIFIC POPULATIONS**-----

Patients with moderate to severe renal impairment should be monitored closely for potential anticholinergic side effects (2, 8.6)

**See 17 for PATIENT COUNSELING INFORMATION and FDA-approved patient labeling.**

**Revised: 2/2018**

**FULL PRESCRIBING INFORMATION: CONTENTS\***

- 1 INDICATIONS AND USAGE**
- 2 DOSAGE AND ADMINISTRATION**
- 3 DOSAGE FORMS AND STRENGTHS**
- 4 CONTRAINDICATIONS**
- 5 WARNINGS AND PRECAUTIONS**
  - 5.1 Not for Acute Use
  - 5.2 Immediate Hypersensitivity Reactions
  - 5.3 Paradoxical Bronchospasm
  - 5.4 Worsening of Narrow-Angle Glaucoma
  - 5.5 Worsening of Urinary Retention
  - 5.6 Renal Impairment
- 6 ADVERSE REACTIONS**
  - 6.1 Clinical Trials Experience
  - 6.2 Postmarketing Experience
- 7 DRUG INTERACTIONS**
  - 7.1 Sympathomimetics, Methylxanthines, Steroids
  - 7.2 Anticholinergics
- 8 USE IN SPECIFIC POPULATIONS**
  - 8.1 Pregnancy

- 8.2 Lactation
- 8.4 Pediatric Use
- 8.5 Geriatric Use
- 8.6 Renal Impairment
- 8.7 Hepatic Impairment

**10 OVERDOSAGE****11 DESCRIPTION****12 CLINICAL PHARMACOLOGY**

- 12.1 Mechanism of Action
- 12.2 Pharmacodynamics
- 12.3 Pharmacokinetics

**13 NONCLINICAL TOXICOLOGY**

- 13.1 Carcinogenesis, Mutagenesis, Impairment of Fertility

**14 CLINICAL STUDIES****16 HOW SUPPLIED/STORAGE AND HANDLING****17 PATIENT COUNSELING INFORMATION**

\*Sections or subsections omitted from the full prescribing information are not listed.

## FULL PRESCRIBING INFORMATION

### 1 INDICATIONS AND USAGE

SPIRIVA HANDIHALER (tiotropium bromide inhalation powder) is indicated for the long-term, once-daily, maintenance treatment of bronchospasm associated with chronic obstructive pulmonary disease (COPD), including chronic bronchitis and emphysema. SPIRIVA HANDIHALER is indicated to reduce exacerbations in COPD patients.

### 2 DOSAGE AND ADMINISTRATION

**For oral inhalation only. Do not swallow SPIRIVA capsules, as the intended effects on the lungs will not be obtained. The contents of the SPIRIVA capsules should only be used with the HANDIHALER device [see Overdosage (10)].**

The recommended dose of SPIRIVA HANDIHALER is two inhalations of the powder contents of one SPIRIVA capsule, once-daily, with the HANDIHALER device [see Patient Counseling Information (17)]. Do not take more than one dose in 24 hours.

For administration of SPIRIVA HANDIHALER, a SPIRIVA capsule is placed into the center chamber of the HANDIHALER device. The SPIRIVA capsule is pierced by pressing and releasing the green piercing button on the side of the HANDIHALER device. The tiotropium formulation is dispersed into the air stream when the patient inhales through the mouthpiece [see Patient Counseling Information (17)].

No dosage adjustment is required for geriatric, hepatically-impaired, or renally-impaired patients. However, patients with moderate to severe renal impairment given SPIRIVA HANDIHALER should be monitored closely for anticholinergic effects [see Warnings and Precautions (5.6), Use in Specific Populations (8.5, 8.6, 8.7), and Clinical Pharmacology (12.3)].

### 3 DOSAGE FORMS AND STRENGTHS

Inhalation Powder: SPIRIVA HANDIHALER consists of SPIRIVA capsules containing tiotropium powder for oral inhalation and a HANDIHALER device. SPIRIVA capsules contain 18 mcg of tiotropium in a light green, hard gelatin capsule with TI 01 printed on one side and Boehringer Ingelheim company logo on the other side. The HANDIHALER device is only intended for use with the SPIRIVA capsules.

### 4 CONTRAINDICATIONS

SPIRIVA HANDIHALER is contraindicated in patients with a hypersensitivity to tiotropium, ipratropium, or any components of this product [see Warnings and Precautions (5.2)]. In clinical trials and postmarketing experience with SPIRIVA HANDIHALER, immediate hypersensitivity reactions, including angioedema (including swelling of the lips, tongue, or throat), itching, or rash have been reported [see Warnings and Precautions (5.2)].

### 5 WARNINGS AND PRECAUTIONS

#### 5.1 Not for Acute Use

SPIRIVA HANDIHALER is intended as a once-daily maintenance treatment for COPD and should not be used for relief of acute symptoms, i.e., as rescue therapy for the treatment of acute episodes of bronchospasm.

#### 5.2 Immediate Hypersensitivity Reactions

Immediate hypersensitivity reactions, including urticaria, angioedema (including swelling of the lips, tongue, or throat), rash, bronchospasm, anaphylaxis, or itching, may occur after administration of SPIRIVA HANDIHALER. If such a reaction occurs, therapy with SPIRIVA HANDIHALER should be stopped at once and alternative treatments should be considered. Given the similar structural formula of atropine to tiotropium, patients with a history of hypersensitivity reactions to atropine or its derivatives should be closely monitored for similar hypersensitivity reactions to SPIRIVA HANDIHALER. In addition, SPIRIVA HANDIHALER should be used with caution in patients with severe hypersensitivity to milk proteins.

#### 5.3 Paradoxical Bronchospasm

Inhaled medicines, including SPIRIVA HANDIHALER, may cause paradoxical bronchospasm. If this occurs, it should be treated immediately with an inhaled short-acting beta<sub>2</sub>-agonist such as albuterol. Treatment with SPIRIVA HANDIHALER should be stopped and other treatments considered.

#### 5.4 Worsening of Narrow-Angle Glaucoma

SPIRIVA HANDIHALER should be used with caution in patients with narrow-angle glaucoma. Prescribers and patients should be alert for signs and symptoms of acute narrow-angle glaucoma (e.g., eye pain or discomfort, blurred vision, visual halos or colored images in association with red eyes from conjunctival congestion and corneal edema). Instruct patients to consult a physician immediately should any of these signs or symptoms develop.

#### 5.5 Worsening of Urinary Retention

SPIRIVA HANDIHALER should be used with caution in patients with urinary retention. Prescribers and patients should be alert for signs and symptoms of urinary retention (e.g., difficulty passing urine, painful urination), especially in patients with prostatic hyperplasia or bladder-neck obstruction. Instruct patients to consult a physician immediately should any of these signs or symptoms develop.

#### 5.6 Renal Impairment

As a predominantly renally excreted drug, patients with moderate to severe renal impairment (creatinine clearance of <60 mL/min) treated with SPIRIVA HANDIHALER should be monitored closely for anticholinergic side effects [see Clinical Pharmacology (12.3)].

### 6 ADVERSE REACTIONS

The following adverse reactions are described, or described in greater detail, in other sections:

- Immediate hypersensitivity reactions [see Warnings and Precautions (5.2)]

- Paradoxical bronchospasm [see Warnings and Precautions (5.3)]
- Worsening of narrow-angle glaucoma [see Warnings and Precautions (5.4)]
- Worsening of urinary retention [see Warnings and Precautions (5.5)]

## 6.1 Clinical Trials Experience

Because clinical trials are conducted under widely varying conditions, the incidence of adverse reactions observed in the clinical trials of a drug cannot be directly compared to the incidences in the clinical trials of another drug and may not reflect the incidences observed in practice.

### 6-Month to 1-Year Trials

The data described below reflect exposure to SPIRIVA HANDIHALER in 2663 patients. SPIRIVA HANDIHALER was studied in two 1-year placebo-controlled trials, two 1-year active-controlled trials, and two 6-month placebo-controlled trials in patients with COPD. In these trials, 1308 patients were treated with SPIRIVA HANDIHALER at the recommended dose of 18 mcg once a day. The population had an age ranging from 39 to 87 years with 65% to 85% males, 95% Caucasian, and had COPD with a mean pre-bronchodilator forced expiratory volume in one second (FEV<sub>1</sub>) percent predicted of 39% to 43%. Patients with narrow-angle glaucoma, or symptomatic prostatic hypertrophy or bladder outlet obstruction were excluded from these trials. An additional 6-month trial conducted in a Veteran's Affairs setting is not included in this safety database because only serious adverse events were collected.

The most commonly reported adverse drug reaction was dry mouth. Dry mouth was usually mild and often resolved during continued treatment. Other reactions reported in individual patients and consistent with possible anticholinergic effects included constipation, tachycardia, blurred vision, glaucoma (new onset or worsening), dysuria, and urinary retention.

Four multicenter, 1-year, placebo-controlled and active-controlled trials evaluated SPIRIVA HANDIHALER in patients with COPD. Table 1 shows all adverse reactions that occurred with a frequency of  $\geq 3\%$  in the SPIRIVA HANDIHALER group in the 1-year placebo-controlled trials where the rates in the SPIRIVA HANDIHALER group exceeded placebo by  $\geq 1\%$ . The frequency of corresponding reactions in the ipratropium-controlled trials is included for comparison.

**Table 1 Adverse Reactions (% Patients) in One-Year COPD Clinical Trials**

Body System (Event)	Placebo-Controlled Trials		Ipratropium-Controlled Trials	
	SPIRIVA (n = 550)	Placebo (n = 371)	SPIRIVA (n = 356)	Ipratropium (n = 179)
<b>Body as a Whole</b>				
Chest Pain (non-specific)	7	5	5	2
Edema, Dependent	5	4	3	5
<b>Gastrointestinal System Disorders</b>				
Dry Mouth	16	3	12	6
Dyspepsia	6	5	1	1
Abdominal Pain	5	3	6	6
Constipation	4	2	1	1
Vomiting	4	2	1	2
<b>Musculoskeletal System</b>				
Myalgia	4	3	4	3
<b>Resistance Mechanism Disorders</b>				
Infection	4	3	1	3
Moniliasis	4	2	3	2
<b>Respiratory System (Upper)</b>				
Upper Respiratory Tract Infection	41	37	43	35
Sinusitis	11	9	3	2
Pharyngitis	9	7	7	3
Rhinitis	6	5	3	2
Epistaxis	4	2	1	1
<b>Skin and Appendage Disorders</b>				
Rash	4	2	2	2
<b>Urinary System</b>				
Urinary Tract Infection	7	5	4	2

Arthritis, coughing, and influenza-like symptoms occurred at a rate of  $\geq 3\%$  in the SPIRIVA HANDIHALER treatment group, but were  $< 1\%$  in excess of the placebo group.

Other reactions that occurred in the SPIRIVA HANDIHALER group at a frequency of 1% to 3% in the placebo-controlled trials where the rates exceeded that in the placebo group include: *Body as a Whole*: allergic reaction, leg pain; *Central and Peripheral Nervous System*: dysphonia, paresthesia; *Gastrointestinal System Disorders*: gastrointestinal disorder not otherwise specified (NOS), gastroesophageal reflux, stomatitis (including ulcerative stomatitis); *Metabolic and Nutritional Disorders*: hypercholesterolemia, hyperglycemia; *Musculoskeletal System Disorders*: skeletal pain; *Cardiac Events*: angina pectoris (including aggravated angina pectoris); *Psychiatric Disorder*: depression; *Infections*: herpes zoster; *Respiratory System Disorder (Upper)*: laryngitis; *Vision Disorder*: cataract. In addition, among the adverse reactions observed in the clinical trials with an incidence of  $< 1\%$  were atrial fibrillation, supraventricular tachycardia, angioedema, and urinary retention.

In the 1-year trials, the incidence of dry mouth, constipation, and urinary tract infection increased with age [see Use in Specific Populations (8.5)].

Two multicenter, 6-month, controlled studies evaluated SPIRIVA HANDIHALER in patients with COPD. The adverse reactions and the incidence rates were similar to those seen in the 1-year controlled trials.

#### 4-Year Trial

The data described below reflect exposure to SPIRIVA HANDIHALER in 5992 COPD patients in a 4-year placebo-controlled trial. In this trial, 2986 patients were treated with SPIRIVA HANDIHALER at the recommended dose of 18 mcg once a day. The population had an age range from 40 to 88 years, was 75% male, 90% Caucasian, and had COPD with a mean pre-bronchodilator FEV<sub>1</sub> percent predicted of 40%. Patients with narrow-angle glaucoma, or symptomatic prostatic hypertrophy or bladder outlet obstruction were excluded from these trials. When the adverse reactions were analyzed with a frequency of  $\geq 3\%$  in the SPIRIVA HANDIHALER group where the rates in the SPIRIVA HANDIHALER group exceeded placebo by  $\geq 1\%$ , adverse reactions included (SPIRIVA HANDIHALER, placebo): pharyngitis (12.5%, 10.8%), sinusitis (6.5%, 5.3%), headache (5.7%, 4.5%), constipation (5.1%, 3.7%), dry mouth (5.1%, 2.7%), depression (4.4%, 3.3%), insomnia (4.4%, 3.0%), and arthralgia (4.2%, 3.1%).

#### Additional Adverse Reactions

Other adverse reactions not previously listed that were reported more frequently in COPD patients treated with SPIRIVA HANDIHALER than placebo include: dehydration, skin ulcer, stomatitis, gingivitis, oropharyngeal candidiasis, dry skin, skin infection, and joint swelling.

### 6.2 Postmarketing Experience

Adverse reactions have been identified during worldwide post-approval use of SPIRIVA HANDIHALER. Because these reactions are reported voluntarily from a population of uncertain size, it is not always possible to reliably estimate their frequency or establish a causal relationship to drug exposure. These adverse reactions are: application site irritation (glossitis, mouth ulceration, and pharyngolaryngeal pain), dizziness, dysphagia, hoarseness, intestinal obstruction including ileus paralytic, intraocular pressure increased, oral candidiasis, palpitations, pruritus, tachycardia, throat irritation, and urticaria.

## 7 DRUG INTERACTIONS

### 7.1 Sympathomimetics, Methylxanthines, Steroids

SPIRIVA HANDIHALER has been used concomitantly with short-acting and long-acting sympathomimetic (beta-agonists) bronchodilators, methylxanthines, and oral and inhaled steroids without increases in adverse reactions.

### 7.2 Anticholinergics

There is potential for an additive interaction with concomitantly used anticholinergic medications. Therefore, avoid coadministration of SPIRIVA HANDIHALER with other anticholinergic-containing drugs as this may lead to an increase in anticholinergic adverse effects [*see Warnings and Precautions (5.4, 5.5) and Adverse Reactions (6)*].

## 8 USE IN SPECIFIC POPULATIONS

### 8.1 Pregnancy

#### Risk Summary

The limited human data with SPIRIVA HANDIHALER use during pregnancy are insufficient to inform a drug-associated risk of adverse pregnancy-related outcomes. Based on animal reproduction studies, no structural abnormalities were observed when tiotropium was administered by inhalation to pregnant rats and rabbits during the period of organogenesis at doses 790 and 8 times, respectively, the maximum recommended human daily inhalation dose (MRHDID). Increased post-implantation loss was observed in rats and rabbits administered tiotropium at maternally toxic doses 430 times and 40 times the MRHDID, respectively [*see Data*].

The estimated background risk of major birth defects and miscarriage for the indicated population is unknown. All pregnancies have a background risk of birth defect, loss or other adverse outcomes. In the U.S. general population, the estimated background risk of major birth defects and miscarriage in clinically recognized pregnancies is 2% to 4% and 15% to 20%, respectively.

#### Data

##### Animal Data

In 2 separate embryo-fetal development studies, pregnant rats and rabbits received tiotropium during the period of organogenesis at doses up to approximately 790 and 8 times the MRHDID, respectively (on a mcg/m<sup>2</sup> basis at inhalation doses of 1471 and 7 mcg/kg/day in rats and rabbits, respectively). No evidence of structural abnormalities was observed in rats or rabbits. However, in rats, tiotropium caused fetal resorption, litter loss, decreases in the number of live pups at birth and the mean pup weights, and a delay in pup sexual maturation at tiotropium doses of approximately 40 times the MRHDID (on a mcg/m<sup>2</sup> basis at a maternal inhalation dose of 78 mcg/kg/day). In rabbits, tiotropium caused an increase in post-implantation loss at a tiotropium dose of approximately 430 times the MRHDID (on a mcg/m<sup>2</sup> basis at a maternal inhalation dose of 400 mcg/kg/day). Such effects were not observed at approximately 5 and 95 times the MRHDID, respectively (on a mcg/m<sup>2</sup> basis at inhalation doses of 9 and 88 mcg/kg/day in rats and rabbits, respectively).

### 8.2 Lactation

#### Risk Summary

There are no data on the presence of tiotropium in human milk, the effects on the breastfed infant, or the effects on milk production. Tiotropium is present in milk of lactating rats; however, due to species-specific differences in lactation physiology, the clinical relevance of these data are not clear [*see Data*]. The developmental and health benefits of breastfeeding should be considered along with the mother's clinical need for SPIRIVA HANDIHALER and any potential adverse effects on the breastfed child from SPIRIVA HANDIHALER or from the underlying maternal condition.

#### Data

The distribution of tiotropium bromide into milk was investigated after a single intravenous administration of 10 mg/kg to lactating rats. Tiotropium and/or its metabolites are present in the milk of lactating rats at concentrations above those in plasma.

#### 8.4 Pediatric Use

SPIRIVA HANDIHALER is not indicated for use in children. The safety and effectiveness of SPIRIVA HANDIHALER in pediatric patients have not been established.

#### 8.5 Geriatric Use

Based on available data, no adjustment of SPIRIVA HANDIHALER dosage in geriatric patients is warranted [see *Clinical Pharmacology (12.3)*].

Of the total number of patients who received SPIRIVA HANDIHALER in the 1-year clinical trials, 426 were <65 years, 375 were 65 to 74 years, and 105 were ≥75 years of age. Within each age subgroup, there were no differences between the proportion of patients with adverse events in the SPIRIVA HANDIHALER and the comparator groups for most events. Dry mouth increased with age in the SPIRIVA HANDIHALER group (differences from placebo were 9.0%, 17.1%, and 16.2% in the aforementioned age subgroups). A higher frequency of constipation and urinary tract infections with increasing age was observed in the SPIRIVA HANDIHALER group in the placebo-controlled studies. The differences from placebo for constipation were 0%, 1.8%, and 7.8% for each of the age groups. The differences from placebo for urinary tract infections were -0.6%, 4.6%, and 4.5%. No overall differences in effectiveness were observed among these groups.

#### 8.6 Renal Impairment

Patients with moderate to severe renal impairment (creatinine clearance of <60 mL/min) treated with SPIRIVA HANDIHALER should be monitored closely for anticholinergic side effects [see *Dosage and Administration (2)*, *Warnings and Precautions (5.6)*, and *Clinical Pharmacology (12.3)*].

#### 8.7 Hepatic Impairment

The effects of hepatic impairment on the pharmacokinetics of tiotropium were not studied.

### 10 OVERDOSAGE

High doses of tiotropium may lead to anticholinergic signs and symptoms. However, there were no systemic anticholinergic adverse effects following a single inhaled dose of up to 282 mcg tiotropium in 6 healthy volunteers. In a study of 12 healthy volunteers, bilateral conjunctivitis and dry mouth were seen following repeated once-daily inhalation of 141 mcg of tiotropium.

Treatment of overdosage consists of discontinuation of SPIRIVA HANDIHALER together with institution of appropriate symptomatic and/or supportive therapy.

#### Accidental Ingestion

**Acute intoxication by inadvertent oral ingestion of SPIRIVA capsules is unlikely since it is not well-absorbed systemically.**

A case of overdose has been reported from postmarketing experience. A female patient was reported to have inhaled 30 capsules over a 2.5 day period, and developed altered mental status, tremors, abdominal pain, and severe constipation. The patient was hospitalized, SPIRIVA HANDIHALER was discontinued, and the constipation was treated with an enema. The patient recovered and was discharged on the same day.

### 11 DESCRIPTION

SPIRIVA HANDIHALER consists of SPIRIVA capsules and a HANDIHALER device. Each light green, hard gelatin SPIRIVA capsule contains a dry powder consisting of 18 mcg tiotropium (equivalent to 22.5 mcg tiotropium bromide monohydrate) blended with lactose monohydrate (which may contain milk proteins).

The contents of SPIRIVA capsules are intended for oral inhalation only, and are intended for administration only with the HANDIHALER device.

The active component of SPIRIVA HANDIHALER is tiotropium. The drug substance, tiotropium bromide monohydrate, is an anticholinergic with specificity for muscarinic receptors. It is chemically described as (1 $\alpha$ , 2 $\beta$ , 4 $\beta$ , 5 $\alpha$ , 7 $\beta$ )-7-[(Hydroxydi-2-thienylacetyl)oxy]-9,9-dimethyl-3-oxa-9-azoniatricyclo[3.3.1.0<sup>2,4</sup>]nonane bromide monohydrate. It is a synthetic, non-chiral, quaternary ammonium compound. Tiotropium bromide is a white or yellowish white powder. It is sparingly soluble in water and soluble in methanol.

The structural formula is:

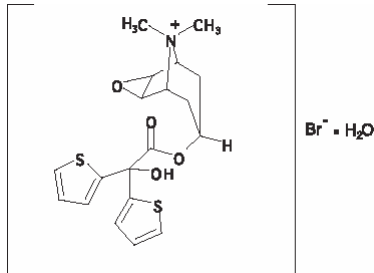

Tiotropium bromide (monohydrate) has a molecular mass of 490.4 and a molecular formula of C<sub>19</sub>H<sub>22</sub>NO<sub>4</sub>S<sub>2</sub>Br · H<sub>2</sub>O.

The HANDIHALER device is an inhalation device used to inhale the dry powder contained in the SPIRIVA capsule. The dry powder is delivered from the HANDIHALER device at flow rates as low as 20 L/min. Under standardized *in vitro* testing, the HANDIHALER device delivers a mean of 10.4 mcg tiotropium when tested at a flow rate of 39 L/min for 3.1 seconds (2 L total). In a study of 26 adult patients with COPD and severely compromised lung function [mean FEV<sub>1</sub> 1.02 L (range 0.45 to 2.24 L); 37.6% of predicted (range 16% to 65%)], the median peak inspiratory flow (PIF) through the HANDIHALER device was 30.0 L/min (range 20.4 to 45.6 L/min). The amount of drug delivered to the lungs will vary depending on patient factors such as inspiratory flow and peak inspiratory flow through the HANDIHALER device, which may vary from patient to patient, and may vary with the exposure time of the SPIRIVA capsule outside the blister pack.

## 12 CLINICAL PHARMACOLOGY

### 12.1 Mechanism of Action

Tiotropium is a long-acting, antimuscarinic agent, which is often referred to as an anticholinergic. It has similar affinity to the subtypes of muscarinic receptors, M<sub>1</sub> to M<sub>5</sub>. In the airways, it exhibits pharmacological effects through inhibition of M<sub>3</sub>-receptors at the smooth muscle leading to bronchodilation. The competitive and reversible nature of antagonism was shown with human and animal origin receptors and isolated organ preparations. In preclinical *in vitro* as well as *in vivo* studies, prevention of methacholine-induced bronchoconstriction effects was dose-dependent and lasted longer than 24 hours. The bronchodilation following inhalation of tiotropium is predominantly a site-specific effect.

### 12.2 Pharmacodynamics

#### Cardiac Electrophysiology

In a multicenter, randomized, double-blind trial using tiotropium dry powder for inhalation that enrolled 198 patients with COPD, the number of subjects with changes from baseline-corrected QT interval of 30 to 60 msec was higher in the SPIRIVA HANDIHALER group as compared with placebo. This difference was apparent using both the Bazett (QTcB) [20 (20%) patients vs. 12 (12%) patients] and Fredericia (QTcF) [16 (16%) patients vs. 1 (1%) patient] corrections of QT for heart rate. No patients in either group had either QTcB or QTcF of >500 msec. Other clinical studies with SPIRIVA HANDIHALER did not detect an effect of the drug on QTc intervals.

The effect of tiotropium dry powder for inhalation on QT interval was also evaluated in a randomized, placebo- and positive-controlled crossover study in 53 healthy volunteers. Subjects received tiotropium dry powder for inhalation 18 mcg, 54 mcg (3 times the recommended dose), or placebo for 12 days. ECG assessments were performed at baseline and throughout the dosing interval following the first and last dose of study medication. Relative to placebo, the maximum mean change from baseline in study-specific QTc interval was 3.2 msec and 0.8 msec for tiotropium dry powder for inhalation 18 mcg and 54 mcg, respectively. No subject showed a new onset of QTc >500 msec or QTc changes from baseline of  $\geq 60$  msec.

### 12.3 Pharmacokinetics

Tiotropium is administered by dry powder inhalation. Some of the pharmacokinetic data described below were obtained with higher doses than recommended for therapy. A dedicated pharmacokinetic study in patients with COPD evaluating once-daily tiotropium delivered from the RESPIMAT inhaler (5 mcg) and as inhalation powder (18 mcg) from the HANDIHALER device resulted in a similar systemic exposure between the two products.

#### Absorption

Following dry powder inhalation by young healthy volunteers, the absolute bioavailability of 19.5% suggests that the fraction reaching the lung is highly bioavailable. Oral solutions of tiotropium have an absolute bioavailability of 2-3%. Food is not expected to influence the absorption of tiotropium. Maximum tiotropium plasma concentrations were observed 7 minutes after inhalation.

#### Distribution

Tiotropium is 72% bound to plasma protein and had a volume of distribution of 32 L/kg after intravenous administration to young healthy volunteers. Local concentrations in the lung are not known, but the mode of administration suggests substantially higher concentrations in the lung. Studies in rats have shown that tiotropium does not readily penetrate the blood-brain barrier.

#### Elimination

The terminal half-life of tiotropium in COPD patients following once daily inhalation of 5 mcg tiotropium was approximately 25 hours. Total clearance was 880 mL/min after intravenous administration in young healthy volunteers. After chronic once-daily dry powder inhalation by COPD patients, pharmacokinetic steady state was reached by day 7 with no accumulation thereafter.

#### Metabolism

The extent of metabolism is small. This is evident from a urinary excretion of 74% of unchanged substance after an intravenous dose to young healthy volunteers. Tiotropium, an ester, is nonenzymatically cleaved to the alcohol N-methylscopine and dithienylglycolic acid, neither of which binds to muscarinic receptors.

*In vitro* experiments with human liver microsomes and human hepatocytes suggest that a fraction of the administered dose (74% of an intravenous dose is excreted unchanged in the urine, leaving 25% for metabolism) is metabolized by cytochrome P450-dependent oxidation and subsequent glutathione conjugation to a variety of Phase II metabolites. This enzymatic pathway can be inhibited by CYP450 2D6 and 3A4 inhibitors, such as quinidine, ketoconazole, and gestodene. Thus, CYP450 2D6 and 3A4 are involved in the metabolic pathway that is responsible for the elimination of a small part of the administered dose. *In vitro* studies using human liver microsomes showed that tiotropium in supra-therapeutic concentrations did not inhibit CYP450 1A1, 1A2, 2B6, 2C9, 2C19, 2D6, 2E1, or 3A4.

#### Excretion

Intravenously administered tiotropium bromide is mainly excreted unchanged in urine (74%). After dry powder inhalation to COPD patients at steady state, urinary excretion was 7% (1.3mcg) of the unchanged dose over 24 hours. The renal clearance of tiotropium exceeds the creatinine clearance, indicating secretion into the urine.

#### Specific Populations

##### Geriatric Patients

As expected for all predominantly renally excreted drugs, advancing age was associated with a decrease of tiotropium renal clearance (365 mL/min in COPD patients <65 years to 271 mL/min in COPD patients  $\geq 65$  years). This did not result in a corresponding increase in AUC<sub>0-6,ss</sub> and C<sub>max,ss</sub> values following administration via HANDIHALER device.

##### Renal Impairment

Following 4-week SPIRIVA HANDIHALER or SPIRIVA RESPIMAT once daily dosing in patients with COPD, mild renal impairment (creatinine clearance 60-<90 mL/min) resulted in 6-23% higher AUC<sub>0-6,ss</sub> and 6-17% higher C<sub>max,ss</sub> values; moderate renal impairment (creatinine clearance 30-<60 mL/min) resulted in 54-57%

higher  $AUC_{0-6,ss}$  and 15-31% higher  $C_{max,ss}$  values compared to COPD patients with normal renal function (creatinine clearance  $\geq 90$  mL/min). There is insufficient data for tiotropium exposure in patients with severe renal impairment (creatinine clearance  $< 30$  mL/min) following inhalation of SPIRIVA HANDIHALER or SPIRIVA RESPIMAT. However  $AUC_{0-4}$  and  $C_{max}$  were 94% and 52% higher, respectively, in patients with severe renal impairment following intravenous infusion of tiotropium bromide.

#### *Hepatic Impairment*

The effects of hepatic impairment on the pharmacokinetics of tiotropium were not studied.

#### Drug Interactions

An interaction study with tiotropium (14.4 mcg intravenous infusion over 15 minutes) and cimetidine 400 mg three times daily or ranitidine 300 mg once daily was conducted. Concomitant administration of cimetidine with tiotropium resulted in a 20% increase in the  $AUC_{0-4h}$ , a 28% decrease in the renal clearance of tiotropium and no significant change in the  $C_{max}$  and amount excreted in urine over 96 hours. Co-administration of tiotropium with ranitidine did not affect the pharmacokinetics of tiotropium.

Common concomitant medications (long-acting beta<sub>2</sub>-adrenergic agonists (LABA), inhaled corticosteroids (ICS)) used by patients with COPD were not found to alter the exposure to tiotropium.

### **13 NONCLINICAL TOXICOLOGY**

#### **13.1 Carcinogenesis, Mutagenesis, Impairment of Fertility**

No evidence of tumorigenicity was observed in a 104-week inhalation study in rats at tiotropium doses up to 59 mcg/kg/day, in an 83-week inhalation study in female mice at doses up to 145 mcg/kg/day, and in a 101-week inhalation study in male mice at doses up to 2 mcg/kg/day. These doses correspond to approximately 30, 40, and 0.5 times the recommended human daily inhalation dose (MRHDID) on a mcg/m<sup>2</sup> basis, respectively.

Tiotropium bromide demonstrated no evidence of mutagenicity or clastogenicity in the following assays: the bacterial gene mutation assay, the V79 Chinese hamster cell mutagenesis assay, the chromosomal aberration assays in human lymphocytes *in vitro* and mouse micronucleus formation *in vivo*, and the unscheduled DNA synthesis in primary rat hepatocytes *in vitro* assay.

In rats, decreases in the number of corpora lutea and the percentage of implants were noted at inhalation tiotropium doses of 78 mcg/kg/day or greater (approximately 40 times the MRHDID on a mcg/m<sup>2</sup> basis). No such effects were observed at 9 mcg/kg/day (approximately 5 times the MRHDID on a mcg/m<sup>2</sup> basis). The fertility index, however, was not affected at inhalation doses up to 1689 mcg/kg/day (approximately 910 times the MRHDID on a mcg/m<sup>2</sup> basis).

### **14 CLINICAL STUDIES**

The SPIRIVA HANDIHALER (tiotropium bromide inhalation powder) clinical development program consisted of six Phase 3 studies in 2663 patients with COPD (1308 receiving SPIRIVA HANDIHALER): two 1-year, placebo-controlled studies, two 6-month, placebo-controlled studies and two 1-year, ipratropium-controlled studies. These studies enrolled patients who had a clinical diagnosis of COPD, were 40 years of age or older, had a history of smoking greater than 10 pack-years, had a forced expiratory volume in one second (FEV<sub>1</sub>) less than or equal to 60% or 65% of predicted, and a ratio of FEV<sub>1</sub>/FVC of less than or equal to 0.7.

In these studies, SPIRIVA HANDIHALER, administered once-daily in the morning, provided improvement in lung function (FEV<sub>1</sub>), with peak effect occurring within 3 hours following the first dose.

Two additional trials evaluated exacerbations: a 6-month, randomized, double-blind, placebo-controlled, multicenter clinical trial of 1829 COPD patients in a US Veterans Affairs setting and a 4-year, randomized, double-blind, placebo-controlled, multicenter, clinical trial of 5992 COPD patients. Long-term effects on lung function and other outcomes, were also evaluated in the 4-year multicenter trial.

#### *6-Month to 1-Year Effects on Lung Function*

In the 1-year, placebo-controlled trials, the mean improvement in FEV<sub>1</sub> at 30 minutes was 0.13 liters (13%) with a peak improvement of 0.24 liters (24%) relative to baseline after the first dose (Day 1). Further improvements in FEV<sub>1</sub> and forced vital capacity (FVC) were observed with pharmacodynamic steady state reached by Day 8 with once-daily treatment. The mean peak improvement in FEV<sub>1</sub>, relative to baseline, was 0.28 to 0.31 liters (28% to 31%), after 1 week (Day 8) of once-daily treatment. Improvement of lung function was maintained for 24 hours after a single dose and consistently maintained over the 1-year treatment period with no evidence of tolerance.

In the two 6-month, placebo-controlled trials, serial spirometric evaluations were performed throughout daytime hours in Trial A (12 hours) and limited to 3 hours in Trial B. The serial FEV<sub>1</sub> values over 12 hours (Trial A) are displayed in Figure 1. These trials further support the improvement in pulmonary function (FEV<sub>1</sub>) with SPIRIVA HANDIHALER, which persisted over the spirometric observational period. Effectiveness was maintained for 24 hours after administration over the 6-month treatment period.

**Figure 1 Mean FEV<sub>1</sub> Over Time (prior to and after administration of study drug) on Days 1 and 169 for Trial A (a Six-Month Placebo-Controlled Study)\***

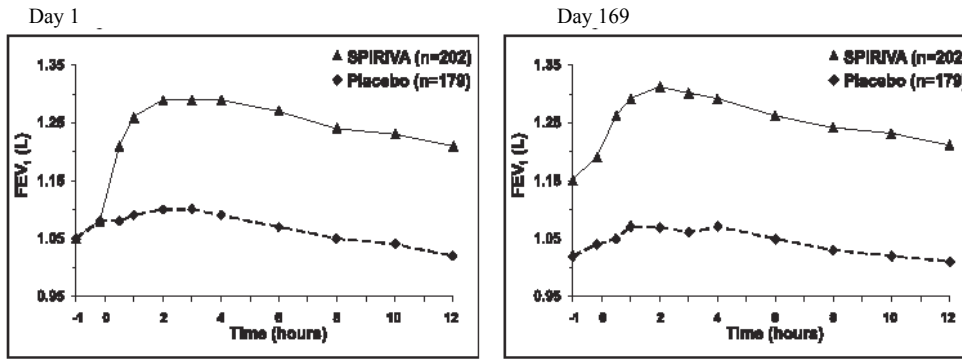

\*Means adjusted for center, treatment, and baseline effect. On Day 169, a total of 183 and 149 patients in the SPIRIVA HANDIHALER and placebo groups, respectively, completed the trial. The data for the remaining patients were imputed using the last observation or least favorable observation carried forward.

Results of each of the 1-year ipratropium-controlled trials were similar to the results of the 1-year placebo-controlled trials. The results of one of these trials are shown in Figure 2.

**Figure 2 Mean FEV<sub>1</sub> Over Time (0 to 6 hours post-dose) on Days 1 and 92, Respectively for One of the Two Ipratropium-Controlled Studies\***

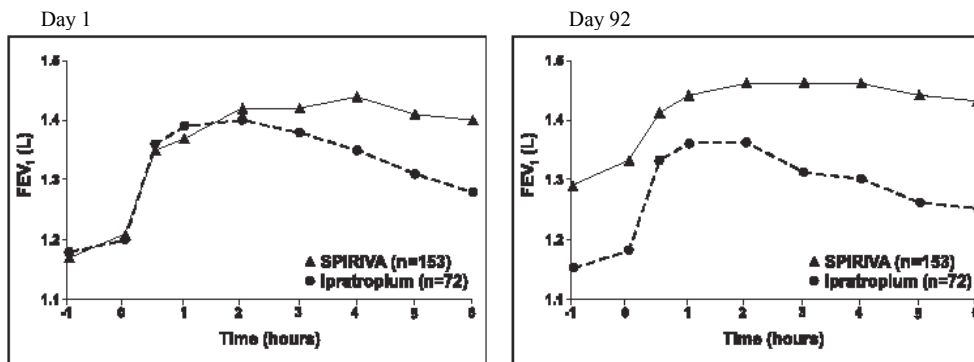

\*Means adjusted for center, treatment, and baseline effect. On Day 92 (primary endpoint), a total of 151 and 69 patients in the SPIRIVA HANDIHALER and ipratropium groups, respectively, completed through 3 months of observation. The data for the remaining patients were imputed using the last observation or least favorable observation carried forward.

A randomized, placebo-controlled clinical study in 105 patients with COPD demonstrated that bronchodilation was maintained throughout the 24-hour dosing interval in comparison to placebo, regardless of whether SPIRIVA HANDIHALER was administered in the morning or in the evening.

Throughout each week of the 1-year treatment period in the two placebo-controlled trials, patients taking SPIRIVA HANDIHALER had a reduced requirement for the use of rescue short-acting beta<sub>2</sub>-agonists. Reduction in the use of rescue short-acting beta<sub>2</sub>-agonists, as compared to placebo, was demonstrated in one of the two 6-month studies.

#### 4-Year Effects on Lung Function

A 4-year, randomized, double-blind, placebo-controlled, multicenter clinical trial involving 5992 COPD patients was conducted to evaluate the long-term effects of SPIRIVA HANDIHALER on disease progression (rate of decline in FEV<sub>1</sub>). Patients were permitted to use all respiratory medications (including short-acting and long-acting beta-agonists, inhaled and systemic steroids, and theophyllines) other than inhaled anticholinergics. The patients were 40 to 88 years of age, 75% male, and 90% Caucasian with a diagnosis of COPD and a mean pre-bronchodilator FEV<sub>1</sub> of 39% predicted (range = 9% to 76%) at study entry. There was no difference between the groups in either of the co-primary efficacy endpoints, yearly rate of decline in pre- and post-bronchodilator FEV<sub>1</sub>, as demonstrated by similar slopes of FEV<sub>1</sub> decline over time (Figure 3).

SPIRIVA HANDIHALER maintained improvements in trough (pre-dose) FEV<sub>1</sub> (adjusted means over time: 87 to 103 mL) throughout the 4 years of the study (Figure 3).

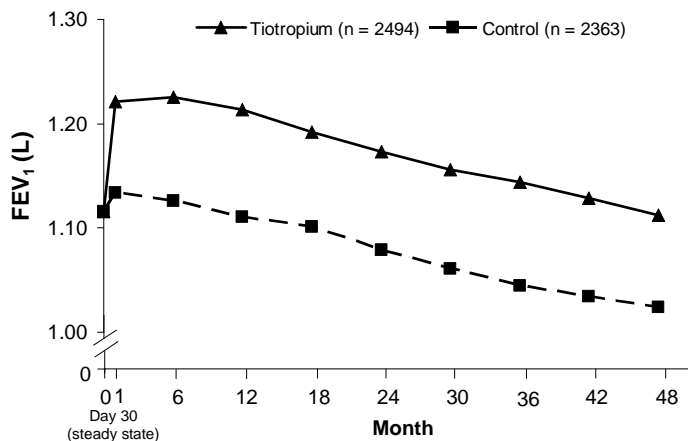

**Figure 3 Trough (pre-dose) FEV<sub>1</sub> Mean Values at Each Time Point**

Repeated measure ANOVA was used to estimate means. Means are adjusted for baseline measurements. Baseline trough FEV<sub>1</sub> (observed mean) = 1.12. Patients with  $\geq 3$  acceptable pulmonary function tests after Day 30 and non-missing baseline value were included in the analysis.

#### Exacerbations

The effect of SPIRIVA HANDIHALER on COPD exacerbations was evaluated in two clinical trials: a 4-year clinical trial described above and a 6-month clinical trial of 1829 COPD patients in a Veterans Affairs setting. In the 6-month trial, COPD exacerbations were defined as a complex of respiratory symptoms (increase or new onset) of more than one of the following: cough, sputum, wheezing, dyspnea, or chest tightness with a duration of at least 3 days requiring treatment with antibiotics, systemic steroids, or hospitalization. The population had an age ranging from 40 to 90 years with 99% males, 91% Caucasian, and had COPD with a mean pre-bronchodilator FEV<sub>1</sub> percent predicted of 36% (range = 8% to 93%). Patients were permitted to use respiratory medications (including short-acting and long-acting beta-agonists, inhaled and systemic steroids, and theophyllines) other than inhaled anticholinergics. In the 6-month trial, the co-primary endpoints were the proportion of patients with COPD exacerbation and the proportion of patients with hospitalization due to COPD exacerbation. SPIRIVA HANDIHALER significantly reduced the proportion of COPD patients who experienced exacerbations compared to placebo (27.9% vs. 32.3%, respectively; Odds Ratio (OR) (tiotropium/placebo) = 0.81; 95% CI = 0.66, 0.99;  $p = 0.037$ ). The proportion of patients with hospitalization due to COPD exacerbations in patients who used SPIRIVA HANDIHALER compared to placebo was 7.0% vs. 9.5%, respectively; OR = 0.72; 95% CI = 0.51, 1.01;  $p = 0.056$ .

Exacerbations were evaluated as a secondary outcome in the 4-year multicenter trial. In this trial, COPD exacerbations were defined as an increase or new onset of more than one of the following respiratory symptoms (cough, sputum, sputum purulence, wheezing, dyspnea) with a duration of three or more days requiring treatment with antibiotics and/or systemic (oral, intramuscular, or intravenous) steroids. SPIRIVA HANDIHALER significantly reduced the risk of an exacerbation by 14% (Hazard Ratio (HR) = 0.86; 95% CI = 0.81, 0.91;  $p < 0.001$ ) and reduced the risk of exacerbation-related hospitalization by 14% (HR = 0.86; 95% CI = 0.78, 0.95;  $p < 0.002$ ) compared to placebo. The median time to first exacerbation was delayed from 12.5 months (95% CI = 11.5, 13.8) in the placebo group to 16.7 months (95% CI = 14.9, 17.9) in the SPIRIVA HANDIHALER group.

#### All-Cause Mortality

In the 4-year placebo-controlled lung-function trial described above, all-cause mortality compared to placebo was assessed. There were no significant differences in all-cause mortality rates between SPIRIVA HANDIHALER and placebo.

The all-cause mortality of SPIRIVA HANDIHALER was also compared to tiotropium inhalation spray 5 mcg (SPIRIVA RESPIMAT 5 mcg) in an additional long-term, randomized, double-blind, double-dummy active-controlled study with an observation period up to 3 years. All-cause mortality was similar between SPIRIVA HANDIHALER and SPIRIVA RESPIMAT.

## 16 HOW SUPPLIED/STORAGE AND HANDLING

SPIRIVA HANDIHALER consists of SPIRIVA capsules and the HANDIHALER device. SPIRIVA capsules contain 18 mcg of tiotropium and are light green, with the Boehringer Ingelheim company logo on the SPIRIVA capsule cap and TI 01 on the SPIRIVA capsule body, or vice versa.

The HANDIHALER device is gray colored with a green piercing button. It is imprinted with SPIRIVA HANDIHALER (tiotropium bromide inhalation powder), the Boehringer Ingelheim company logo. It is also imprinted to indicate that SPIRIVA capsules should not be stored in the HANDIHALER device and that the HANDIHALER device is only to be used with SPIRIVA capsules.

SPIRIVA capsules are packaged in an aluminum/aluminum blister card and joined along a perforated-cut line. SPIRIVA capsules should always be stored in the blister and only removed immediately before use. The drug should be used immediately after the packaging over an individual SPIRIVA capsule is opened.

The following packages are available:

- carton containing 5 SPIRIVA capsules (1 unit-dose blister card) and 1 HANDIHALER inhalation device (NDC 0597-0075-75) (institutional pack)
- carton containing 30 SPIRIVA capsules (3 unit-dose blister cards) and 1 HANDIHALER inhalation device (NDC 0597-0075-41)
- carton containing 90 SPIRIVA capsules (9 unit-dose blister cards) and 1 HANDIHALER inhalation device (NDC 0597-0075-47)

Keep out of reach of children. Do not get powder into eyes.

*Storage*

Store at 25°C (77°F); excursions permitted to 15° to 30°C (59° to 86°F) [see USP Controlled Room Temperature].

The SPIRIVA capsules should not be exposed to extreme temperature or moisture. Do not store SPIRIVA capsules in the HANDIHALER device.

**17 PATIENT COUNSELING INFORMATION**

Advise the patient to read the FDA-approved patient labeling (Patient Information and Instructions for Use).

Not for Acute Use:

Instruct patients that SPIRIVA HANDIHALER is a once-daily maintenance bronchodilator and should not be used for immediate relief of breathing problems (i.e., as a rescue medication).

Immediate Hypersensitivity Reactions:

Inform patients that anaphylaxis, angioedema (including swelling of the lips, tongue, or throat), urticaria, rash, bronchospasm, or itching, may occur after administration of SPIRIVA HANDIHALER. Advise patient to immediately discontinue treatment and consult a physician should any of these signs or symptoms develop.

Paradoxical Bronchospasm:

Inform patients that SPIRIVA HANDIHALER can produce paradoxical bronchospasm. Advise patients that if paradoxical bronchospasm occurs, patients should discontinue SPIRIVA HANDIHALER.

Worsening of Narrow-Angle Glaucoma:

Instruct patients to be alert for signs and symptoms of narrow-angle glaucoma (e.g., eye pain or discomfort, blurred vision, visual halos or colored images in association with red eyes from conjunctival congestion and corneal edema). Instruct patients to consult a physician immediately should any of these signs and symptoms develop.

Inform patients that care must be taken not to allow the powder to enter into the eyes as this may cause blurring of vision and pupil dilation.

Since dizziness and blurred vision may occur with the use of SPIRIVA HANDIHALER, caution patients about engaging in activities such as driving a vehicle or operating appliances or machinery.

Worsening of Urinary Retention:

Instruct patients to be alert for signs and symptoms of urinary retention (e.g., difficulty passing urine, painful urination). Instruct patients to consult a physician immediately should any of these signs or symptoms develop.

Instructions for Administering SPIRIVA HANDIHALER:

Instruct patients on how to correctly administer SPIRIVA capsules using the HANDIHALER device [see *Patient Counseling Information (17)*]. Instruct patients that SPIRIVA capsules should only be administered via the HANDIHALER device and the HANDIHALER device should not be used for administering other medications. **Remind patients that the contents of SPIRIVA capsules are for oral inhalation only and must not be swallowed.**

Instruct patients always to store SPIRIVA capsules in sealed blisters and to remove only one SPIRIVA capsule immediately before use or its effectiveness may be reduced. Instruct patients to discard unused additional SPIRIVA capsules that are exposed to air (i.e., not intended for immediate use).

Distributed by:

Boehringer Ingelheim Pharmaceuticals, Inc.  
Ridgefield, CT 06877 USA

**Address medical inquiries to: (800) 542-6257 or (800) 459-9906 TTY.**

SPIRIVA® and HANDIHALER® are registered trademarks and are used under license from Boehringer Ingelheim International GmbH.

Copyright © 2018 Boehringer Ingelheim International GmbH  
ALL RIGHTS RESERVED

IT5300LA312018

## Patient Information

**SPIRIVA® (speh REE vah) HANDIHALER®**  
(tiotropium bromide inhalation powder)



**Do NOT swallow SPIRIVA capsules.**

**Important Information:** Do not swallow SPIRIVA capsules. SPIRIVA capsules should only be used with the HANDIHALER device and inhaled through your mouth (oral inhalation).

Read the information that comes with your SPIRIVA HANDIHALER before you start using it and each time you refill your prescription. There may be new information. This leaflet does not take the place of talking with your doctor about your medical condition or your treatment.

### What is SPIRIVA HANDIHALER?

- SPIRIVA HANDIHALER is a prescription medicine used each day (a maintenance medicine) to control symptoms of chronic obstructive pulmonary disease (COPD), including chronic bronchitis and emphysema.
- SPIRIVA HANDIHALER helps make your lungs work better for 24 hours. SPIRIVA HANDIHALER relaxes your airways and helps keep them open. You may start to feel like it is easier to breathe on the first day, but it may take longer for you to feel the full effects of the medicine. SPIRIVA HANDIHALER works best and may help make it easier to breathe when you use it every day.
- SPIRIVA HANDIHALER reduces the likelihood of flare-ups and worsening of COPD symptoms (COPD exacerbations). A COPD exacerbation is defined as an increase or new onset of more than one COPD symptom such as cough, mucus, shortness of breath, and wheezing that requires medicine beyond your rescue medicine.

**SPIRIVA HANDIHALER is not a rescue medicine and should not be used for treating sudden breathing problems.** Your doctor may give you other medicine to use for sudden breathing problems.

It is not known if SPIRIVA HANDIHALER is safe and effective in children.

### Who should not take SPIRIVA HANDIHALER?

#### Do not use SPIRIVA HANDIHALER if you:

- are allergic to tiotropium, ipratropium (Atrovent®), or any of the ingredients in SPIRIVA HANDIHALER. See the end of this leaflet for a complete list of ingredients in SPIRIVA HANDIHALER.

Symptoms of a serious allergic reaction to SPIRIVA HANDIHALER may include:

- raised red patches on your skin (hives)
- itching
- rash
- swelling of the face, lips, tongue, and throat that may cause difficulty in breathing or swallowing

If you have these symptoms of an allergic reaction, stop taking SPIRIVA HANDIHALER and call your doctor right away or go to the nearest hospital emergency room.

### What should I tell my doctor before using SPIRIVA HANDIHALER?

**Before taking SPIRIVA HANDIHALER, tell your doctor about all your medical conditions, including if you:**

- have kidney problems.
- have glaucoma. SPIRIVA HANDIHALER may make your glaucoma worse.
- have an enlarged prostate, problems passing urine, or a blockage in your bladder. SPIRIVA HANDIHALER may make these problems worse.
- are pregnant or plan to become pregnant. It is not known if SPIRIVA HANDIHALER could harm your unborn baby.
- are breast-feeding or plan to breast-feed. It is not known if SPIRIVA HANDIHALER passes into breast milk. You and your doctor will decide if SPIRIVA HANDIHALER is right for you while you breast-feed.
- have a severe allergy to milk proteins. Ask your doctor if you are not sure.

**Tell your doctor about all the medicines you take**, including prescription and non-prescription medicines and eye drops, vitamins, and herbal supplements. Some of your other medicines or supplements may affect the way SPIRIVA HANDIHALER works. SPIRIVA HANDIHALER is an anticholinergic medicine. You should not take other anticholinergic medicines while using SPIRIVA HANDIHALER, including ipratropium. Ask your doctor or pharmacist if you are not sure if one of your medicines is an anticholinergic.

Know the medicines you take. Keep a list of your medicines with you to show your doctor and pharmacist when you get a new medicine.

### How should I take SPIRIVA HANDIHALER?

- Use SPIRIVA HANDIHALER exactly as prescribed. Use SPIRIVA HANDIHALER one time every day.
- Read the “Instructions for Use” at the end of this leaflet before you use SPIRIVA HANDIHALER. Talk with your doctor if you do not understand the instructions.
- **Do not swallow SPIRIVA capsules.**
- **Only use SPIRIVA capsules with the HANDIHALER device.**
- **Do not use the HANDIHALER device to take any other medicine.**
- SPIRIVA HANDIHALER comes as a powder in a SPIRIVA capsule that fits the HANDIHALER device. Each SPIRIVA capsule, containing only a small amount of SPIRIVA powder, is one full dose of medicine.
- Separate one blister from the blister card. Then take out one of the SPIRIVA capsules from the blister package right before you use it.
- After the capsule is pierced, take a complete dose of SPIRIVA HANDIHALER by breathing in the powder by mouth two times, using the HANDIHALER device (take 2 inhalations from one SPIRIVA capsule). See the **“Instructions for Use”** at the end of this leaflet.
- Throw away any SPIRIVA capsule that is not used right away after it is taken out of the blister package. Do not leave the SPIRIVA capsules open to air; they may not work as well.
- If you miss a dose, take it as soon as you remember. Do not use SPIRIVA HANDIHALER more than one time every 24 hours.
- If you use more than your prescribed dose of SPIRIVA HANDIHALER, call your doctor or a poison control center.

### What should I avoid while using SPIRIVA HANDIHALER?

- Do not let the powder from the SPIRIVA capsule get into your eyes. Your vision may get blurry and the pupil in your eye may get larger (dilate). If this happens, call your doctor.
- SPIRIVA HANDIHALER can cause dizziness and blurred vision. Should you experience these symptoms you should use caution when engaging in activities such as driving a car or operating appliances or other machines.

### What are the possible side effects of SPIRIVA HANDIHALER?

**SPIRIVA HANDIHALER can cause serious side effects, including: Allergic reaction.** Symptoms may include:

- raised red patches on your skin (hives)
- itching
- rash
- swelling of the lips, tongue, or throat that may cause difficulty in breathing or swallowing

If you have these symptoms of an allergic reaction, stop taking SPIRIVA HANDIHALER and call your doctor right away or

go to the nearest hospital emergency room.

- **Sudden narrowing and blockage of the airways into the lungs (bronchospasm).** Your breathing suddenly gets worse.

If you have these symptoms of bronchospasm, stop taking SPIRIVA HANDIHALER and call your doctor right away or go to the nearest hospital emergency room.

- **New or worsened increased pressure in the eyes (acute narrow-angle glaucoma).** Symptoms of acute narrow-angle glaucoma may include:
  - eye pain
  - blurred vision
  - seeing halos (visual halos) or colored images along with red eyes

Using only eye drops to treat these symptoms may not work. If you have these symptoms, stop taking SPIRIVA HANDIHALER and call your doctor right away.

- **New or worsened urinary retention.** Symptoms of blockage in your bladder and/or enlarged prostate may include: difficulty passing urine, painful urination.

If you have these symptoms of urinary retention, stop taking SPIRIVA HANDIHALER and call your doctor right away.

Other side effects with SPIRIVA HANDIHALER include:

- upper respiratory tract infection
- dry mouth
- sinus infection
- sore throat
- non-specific chest pain
- urinary tract infection
- indigestion
- runny nose
- constipation
- increased heart rate
- blurred vision

These are not all the possible side effects with SPIRIVA HANDIHALER. Tell your doctor if you have any side effect that bothers you or that does not go away.

Call your doctor for medical advice about side effects. You may report side effects to FDA at 1-800-FDA-1088.

#### **How do I store SPIRIVA HANDIHALER?**

- **Do not store SPIRIVA capsules in the HANDIHALER device.**
- Store SPIRIVA capsules in the sealed blister package at room temperature 68°F to 77°F (20°C to 25°C).
- Keep SPIRIVA capsules away from heat and cold (do not freeze).
- Store SPIRIVA capsules in a dry place. Throw away any unused SPIRIVA capsules that have been open to air.

Ask your doctor or pharmacist if you have any questions about storing your SPIRIVA capsules.

**Keep SPIRIVA HANDIHALER, SPIRIVA capsules, and all medicines out of the reach of children.**

#### **General information about SPIRIVA HANDIHALER**

Medicines are sometimes prescribed for purposes other than those listed in Patient Information leaflets. Do not use SPIRIVA HANDIHALER for a purpose for which it has not been prescribed. Do not give SPIRIVA HANDIHALER to other people even if they have the same symptoms that you have. It may harm them.

For more information about SPIRIVA HANDIHALER, talk with your doctor. You can ask your doctor or pharmacist for information about SPIRIVA HANDIHALER that is written for health professionals.

For more information about SPIRIVA HANDIHALER, go to [www.SPIRIVA.com](http://www.SPIRIVA.com), or scan the code below, or call Boehringer Ingelheim Pharmaceuticals, Inc. at 1-800-542-6257 or (TTY) 1-800-459-9906.



**What are the ingredients in SPIRIVA HANDIHALER?**

Active ingredient: tiotropium

Inactive ingredient: lactose monohydrate

**What is COPD (Chronic Obstructive Pulmonary Disease)?**

COPD is a serious lung disease that includes chronic bronchitis, emphysema, or both. Most COPD is caused by smoking. When you have COPD, your airways become narrow. So, air moves out of your lungs more slowly. This makes it hard to breathe.

This Patient Information has been approved by the U.S. Food and Drug Administration.

Distributed by:

Boehringer Ingelheim Pharmaceuticals, Inc.  
Ridgefield, CT 06877 USA

Licensed from:

Boehringer Ingelheim International GmbH

SPIRIVA® and HANDIHALER® are registered trademarks and are used under license from Boehringer Ingelheim International GmbH.

Copyright © 2018 Boehringer Ingelheim International GmbH  
ALL RIGHTS RESERVED

Revised: February 2018

IT5300LA312018

## Instructions for Use

**SPIRIVA®** (speh REE vah) **HANDIHALER®**  
(tiotropium bromide inhalation powder)

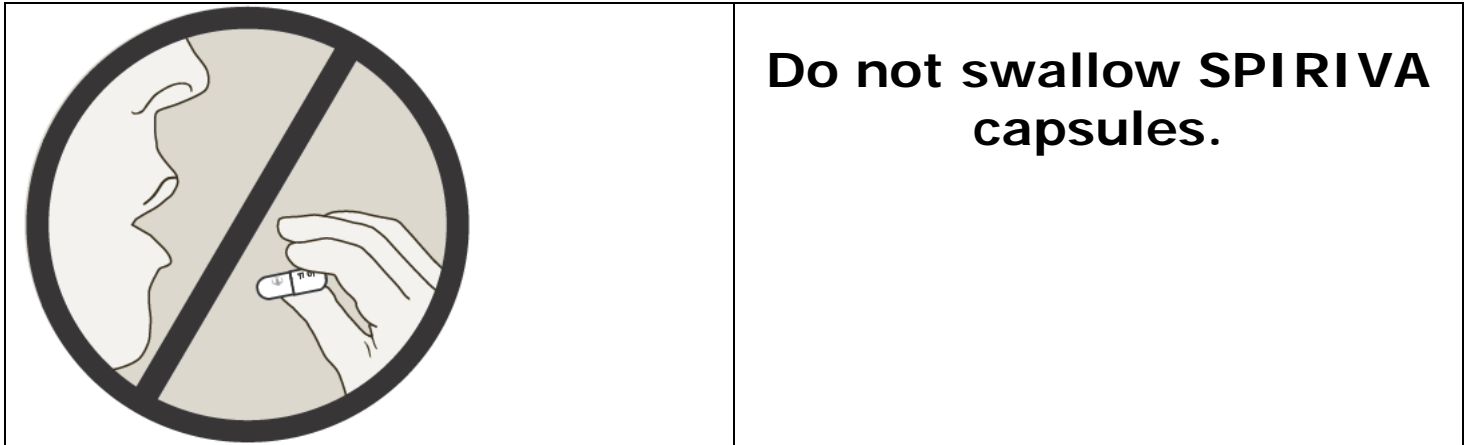

### Important Information about using your SPIRIVA HANDIHALER

- Do not swallow SPIRIVA capsules.
- SPIRIVA capsules should only be used with the HANDIHALER device and inhaled through your mouth (oral inhalation).
- Do not use your HANDIHALER device to take any other medicine.

First read the Patient Information, then read these Instructions for Use before you start to use SPIRIVA HANDIHALER and each time you refill your prescription. There may be new information.

### Becoming familiar with your HANDIHALER device and SPIRIVA capsules:

Your SPIRIVA HANDIHALER comes with SPIRIVA capsules in blister packaging and a HANDIHALER device. Use the new HANDIHALER device provided with your medicine.

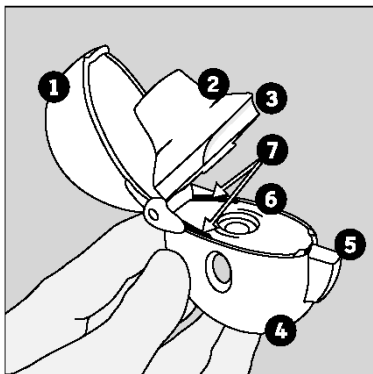

**The parts of your HANDIHALER device include:**  
(See Figure A)

1. dust cap (lid)
2. mouthpiece
3. mouthpiece ridge
4. base
5. green piercing button
6. center chamber
7. air intake vents

Figure A

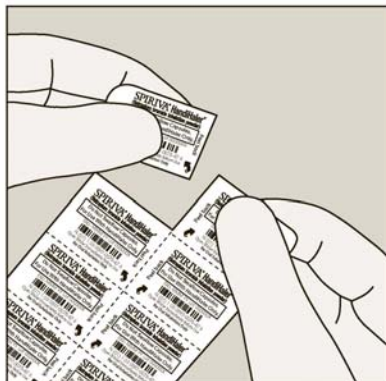

Each SPIRIVA capsule is packaged in a blister. (See Figure B)

Figure B

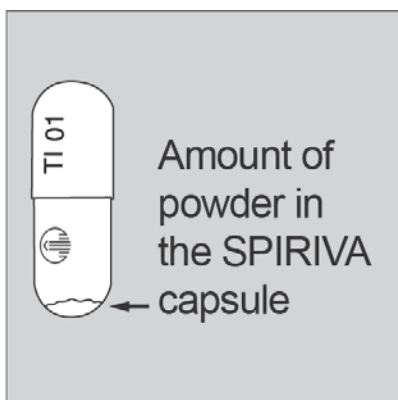

- Each SPIRIVA capsule contains only a small amount of powder. (See Figure C) This is 1 full dose.
- **Do not open the SPIRIVA capsule** or it may not work.

Figure C

**Taking your full daily dose of medicine requires 4 main steps.**

**Step 1. Opening your HANDIHALER device:**

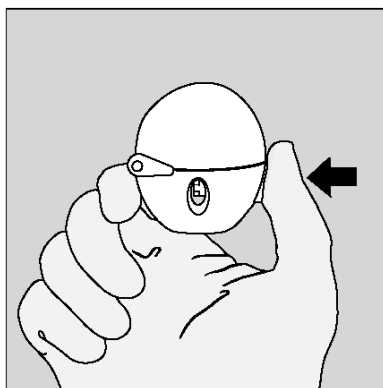

After removing your HANDIHALER device from the pouch:

- Open the dust cap (lid) by pressing the green piercing button. (See Figure D)

Figure D



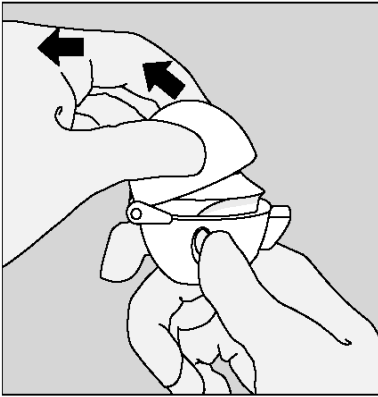

Figure E

- Pull the dust cap (lid) upwards away from the base to expose the mouthpiece. (See Figure E)

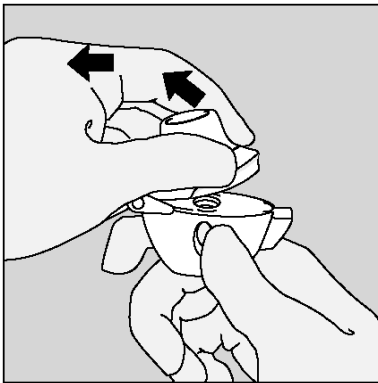

Figure F

- Open the mouthpiece by pulling the mouthpiece ridge up and away from the base so the center chamber is showing. (See Figure F)

**Step 2. Inserting the SPIRIVA capsule into your HANDIHALER device:**

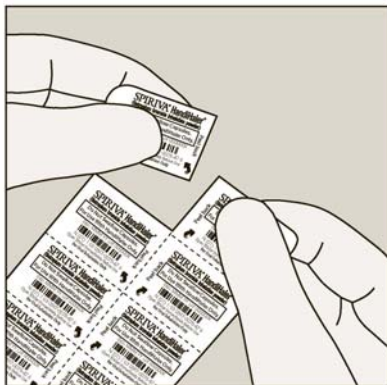

Figure G

Each day, separate only 1 of the blisters from the blister card by tearing along the perforated line. (See Figure G)



Figure H

**Remove the SPIRIVA capsule from the blister:**

- **Do not** cut the foil or use sharp instruments to take out the SPIRIVA capsule from the blister.
- Bend 1 of the blister corners with an arrow and separate the aluminum foil layers.
- Peel back the printed foil until you see the whole SPIRIVA capsule. (See Figure H)
- If you have opened more than 1 blister to the air, the extra SPIRIVA capsule should not be used and should be thrown away.

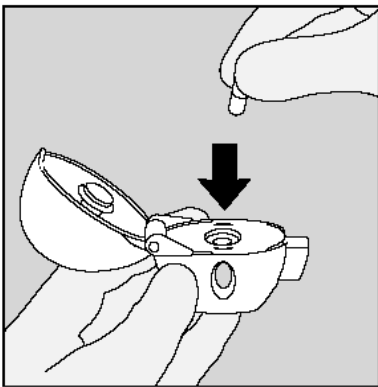

Figure I

Place the SPIRIVA capsule in the center chamber of your HANDIHALER device. (See Figure I)

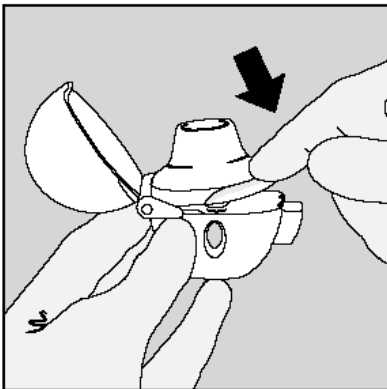

Figure J

Close the mouthpiece firmly against the gray base until you hear a click. Leave the dust cap (lid) open. (See Figure J)

### Step 3. Piercing the SPIRIVA capsule:

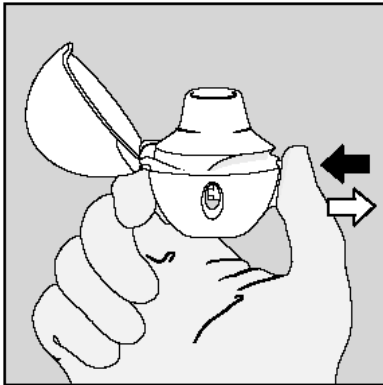

Figure K

- Hold your HANDIHALER device with the mouthpiece pointed up. (See Figure K)
- Press the green piercing button once until it is flat (flush) against the base, then release. This is how you make holes in the SPIRIVA capsule so that you get your medicine when you breathe in.
- **Do not** press the green button more than one time.
- **Do not** shake your HANDIHALER device.
- The piercing of the SPIRIVA capsule may produce small gelatin pieces. Some of these small pieces may pass through the screen of your HANDIHALER device into your mouth or throat when you breathe in your medicine. This is normal. The small pieces of gelatin should not harm you.

### Step 4. Taking your full daily dose (2 inhalations from the same SPIRIVA capsule):

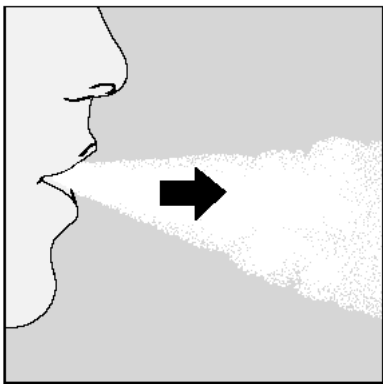

Figure L

**Breathe out completely in 1 breath**, emptying your lungs of any air. (See Figure L)

**Important: Do not** breathe into your HANDIHALER device.

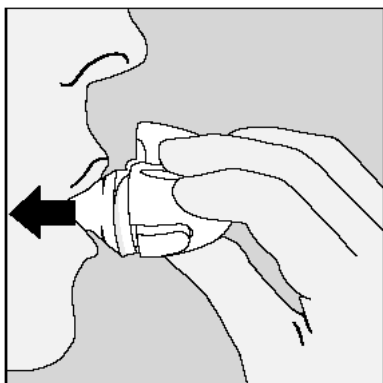

Figure M

**With your next breath, take your medicine:**

- **Hold your head in an upright position while you are looking straight ahead.** (See Figure M)
- Raise your HANDIHALER device to your mouth in a horizontal position. **Do not** block the air intake vents.
- Close your lips tightly around the mouthpiece.
- **Breathe in deeply** until your lungs are full. You should **hear or feel the SPIRIVA capsule vibrate** (rattle). (See Figure M)
- Hold your breath for a few seconds and, at the same time, take your HANDIHALER device out of your mouth.
- Breathe normally again.

The rattle tells you that you breathed in correctly. If you do not hear or feel a rattle, see the section, "If you do not hear or feel the SPIRIVA capsule rattle as you breathe in your medicine."

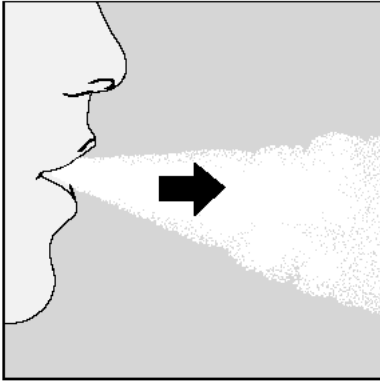

Figure N

To get your full daily dose, you must again, breathe out completely (See Figure N) and for a second time, breathe in (See Figure O) from the same SPIRIVA capsule.

**Important:** Do not press the green piercing button again.

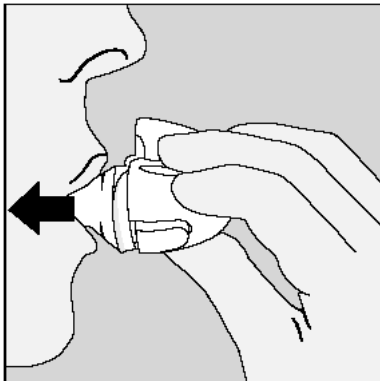

Figure O

**Remember:** To get your full medicine dose each day, you must breathe in 2 times from the same SPIRIVA capsule. Make sure you breathe out completely each time before you breathe in from your HANDIHALER device.

**Caring for and storing your SPIRIVA HANDIHALER:**

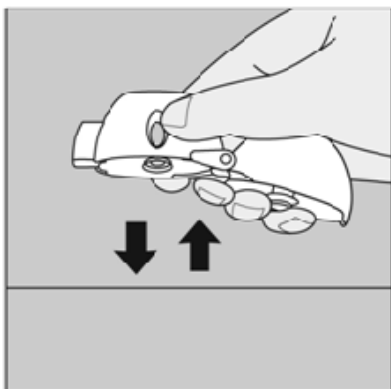

Figure P

- After taking your daily dose, open the mouthpiece and tip out the used SPIRIVA capsule into your trash can, without touching it.
- Remove any SPIRIVA capsule pieces or SPIRIVA powder buildup by turning your HANDIHALER device upside down and gently, but firmly, tapping it. (See Figure P) Then, close the mouthpiece and dustcap for storage.
- **Do not** store your HANDIHALER device and SPIRIVA capsules (blisters) in a damp moist place. Always store SPIRIVA capsules in the sealed blisters.

**If you do not hear or feel the SPIRIVA capsule rattle as you breathe in your medicine:**

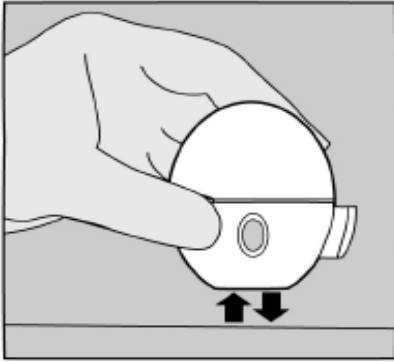

Figure Q

**Do not** press the green piercing button again.

Hold your HANDIHALER device with the mouthpiece pointed up and tap your HANDIHALER device gently on a table. (See Figure Q)

Check to see that the mouthpiece is completely closed. Breathe out completely before deeply breathing in again with the mouthpiece in your mouth. (See Figure O)

If you still do not hear or feel the SPIRIVA capsule rattle after repeating the above steps:

- Throw away the SPIRIVA capsule.
- Open the base by lifting the green piercing button and check the center chamber for pieces of the SPIRIVA capsule. SPIRIVA capsule pieces in the center chamber can cause a SPIRIVA capsule not to rattle.
- Turn your HANDIHALER device upside down and gently, but firmly, tap to remove the SPIRIVA capsule pieces. Call your doctor for instructions.

**Cleaning your HANDIHALER device:**

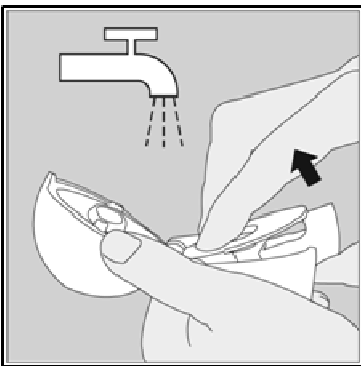

Figure R

Clean your HANDIHALER device as needed. (See Figure R)

- **It takes 24 hours to air dry your HANDIHALER device** after you clean it.
- **Do not** use cleaning agents or detergents.
- **Do not** place your HANDIHALER device in the dishwasher for cleaning.

Cleaning Steps:

- Open the dust cap and mouthpiece.
- Open the base by lifting the green piercing button.
- Look in the center chamber for SPIRIVA capsule pieces or powder buildup. If seen, tap out.
- Rinse your HANDIHALER device with warm water, pressing the green piercing button a few times so that the center chamber and the piercing needle is under the running water. Check that any powder buildup or SPIRIVA capsule pieces are removed.
- Dry your HANDIHALER device well by tipping the excess water out on a paper towel. Air-dry afterwards, leaving the dust cap, mouthpiece, and base open by fully spreading it out so that it dries completely.
- **Do not** use a hair dryer to dry your HANDIHALER device.
- **Do not** use your HANDIHALER device when it is wet. If needed, you may clean the outside of the mouthpiece with a clean damp cloth.

**Helpful Hints** to help ensure that you are properly taking your full daily dose of SPIRIVA HANDIHALER:

- **Press** the green piercing button **1 time**; **Breathe in 2 times**; **Breathe out completely** before each of the **2** inhalations.
- Always use the new HANDIHALER device provided with your medicine.
- Keep your HANDIHALER device with the mouthpiece pointed up when pressing the green piercing button.
- **Press the green piercing button 1 time** to pierce the SPIRIVA capsule.
- Do not breathe out into your HANDIHALER device.
- Keep your HANDIHALER device in a horizontal position and keep your head upright, looking straight ahead, when breathing in.
- Check the center chamber of your HANDIHALER device for SPIRIVA capsule pieces or powder build-up. If pieces or powder are seen, tap out before use.
- Clean your HANDIHALER as needed and dry thoroughly.

For more information, ask your doctor or pharmacist, or go to [www.spiriva.com](http://www.spiriva.com), or scan the code below, or call 1-800-542-6257 or (TTY) 1-800-459-9906.



This Instructions for Use has been approved by the U.S. Food and Drug Administration.

Distributed by:  
Boehringer Ingelheim Pharmaceuticals, Inc.  
Ridgefield, CT 06877 USA

Licensed from:  
Boehringer Ingelheim International GmbH

SPIRIVA® and HANDIHALER® are registered trademarks and are used under license from  
Boehringer Ingelheim International GmbH.

Copyright © 2018 Boehringer Ingelheim International GmbH  
ALL RIGHTS RESERVED

Revised: February 2018

IT5300LA312018

# **EXHIBIT B**



US007070800B2

(12) **United States Patent**  
**Bechtold-Peters et al.**

(10) **Patent No.:** **US 7,070,800 B2**  
(45) **Date of Patent:** **Jul. 4, 2006**

- (54) **INHALABLE POWDER CONTAINING TIOTROPIUM**
- (75) Inventors: **Karoline Bechtold-Peters**, Biberach (DE); **Michael Walz**, Bingen (DE); **Georg Boeck**, Mainz (DE); **Rolf Doerr**, Ober-Olm (DE)
- (73) Assignee: **Boehringer Ingelheim Pharma KG**, Ingelheim (DE)
- (\* ) Notice: Subject to any disclaimer, the term of this patent is extended or adjusted under 35 U.S.C. 154(b) by 103 days.

6,482,429	B1	11/2002	Etzler
6,486,321	B1	11/2002	Banholzer et al.
6,506,900	B1	1/2003	Banholzer et al.
6,517,865	B1	2/2003	Cade et al.
6,585,959	B1	7/2003	Walz et al.
6,589,536	B1	7/2003	Brox et al.
6,645,466	B1	11/2003	Keller et al.
6,881,422	B1	4/2005	Banholzer et al.
6,905,239	B1	6/2005	Boeck et al.
2003/0043687	A1	3/2003	Boeck et al.
2003/0068278	A1	4/2003	Boeck et al.
2003/0070679	A1	4/2003	Hochrainer et al.
2003/0125350	A1	7/2003	Hassan et al.
2003/0202944	A1	10/2003	Staniforth
2003/0235538	A1	12/2003	Zierenberg
2004/0002510	A1	1/2004	Bender et al.
2004/0002548	A1	1/2004	Bozung et al.
2004/0029907	A1	2/2004	Banholzer et al.
2004/0136919	A1	7/2004	Hartig et al. .... 424/46

(21) Appl. No.: **09/975,418**  
(22) Filed: **Oct. 11, 2001**

(65) **Prior Publication Data**

US 2002/0110529 A1 Aug. 15, 2002

**Related U.S. Application Data**

(60) Provisional application No. 60/252,683, filed on Nov. 22, 2000.

(30) **Foreign Application Priority Data**

Oct. 12, 2000 (DE) ..... 100 50 635

(51) **Int. Cl.**

**A61F 13/02** (2006.01)  
**A61F 9/66** (2006.01)  
**A61F 9/14** (2006.01)  
**A61L 9/04** (2006.01)

- (52) **U.S. Cl.** ..... **424/434**; 424/46; 424/435; 424/489; 424/493; 424/451; 424/456
- (58) **Field of Classification Search** ..... 424/489, 424/493, 46, 434, 435, 451, 456  
See application file for complete search history.

(56) **References Cited**

U.S. PATENT DOCUMENTS

3,634,582	A	1/1972	Hartley et al.
3,860,618	A	1/1975	Hartley et al.
3,957,965	A	5/1976	Hartley et al.
4,042,700	A	8/1977	Banholzer et al.
4,608,377	A	8/1986	Banholzer et al.
4,783,534	A	11/1988	Banholzer
5,478,578	A	12/1995	Arnold et al.
5,498,422	A	3/1996	Nakamichi et al.
5,610,163	A	3/1997	Banholzer et al.
5,654,314	A	8/1997	Banholzer et al.
5,770,738	A	6/1998	Banholzer et al.
5,947,118	A	9/1999	Hochrainer et al.
5,952,505	A	9/1999	Banholzer
6,183,782	B1	2/2001	Hallworth
6,221,338	B1	4/2001	Staniforth
6,228,394	B1 *	5/2001	Horhota et al. .... 424/456
6,235,725	B1 *	5/2001	Ahmed ..... 514/56
6,274,287	B1	8/2001	Moriuma et al.

FOREIGN PATENT DOCUMENTS

EP	0 172 258	2/1985
EP	0 418 716	9/1990
FR	8.142 M A	8/1970
WO	WO 93/11746 A1	6/1993
WO	WO 94/28956	12/1994
WO	WO 95/11666 A1	5/1995
WO	WO 95/24889 A1	9/1995
WO	WO 96/02231	2/1996
WO	WO 00/28979 A1	5/2000
WO	WO 00/47200 A1	8/2000
WO	WO 02/30389	4/2002
WO	WO 02/098874	12/2002
WO	WO 03/084502	10/2003
WO	WO 03/084509	10/2003

OTHER PUBLICATIONS

Walz, M. et al; "Process for Preparing Powder Formulations"; USSN 09/977,911; Oct. 11, 2001.  
U.S. Appl. No. 09/961,822; filed Sep. 24, 2001; Banholzer, et al.  
N.H. Shah, et al. "Elasticity of Soft Gelatin Capsules Containing Polyethylene Glycol 400 -Quantitation and Resolution" *Pharmaceutical Technology*, pp. 126-133, Mar. 1992.  
Mareke Hartig, et al. "New Tiotropium Containing Powder Formulation for Inhalation" New U.S. Appl. No. 10/718, 404, filed Nov. 20, 2003.

\* cited by examiner

*Primary Examiner*—Carlos A. Azpuru  
(74) *Attorney, Agent, or Firm*—Michael Morris; Mary-Ellen M. Devlin; Andrea D. Small

(57) **ABSTRACT**

The invention relates to powdered preparations containing tiotropium for inhalation, processes for preparing them as well as their use in preparing a pharmaceutical composition for the treatment of respiratory complaints, particularly for the treatment of COPD (chronic obstructive pulmonary disease) and asthma.

**41 Claims, No Drawings**



US 7,070,800 B2

1

## INHALABLE POWDER CONTAINING TIOTROPIUM

### RELATED APPLICATIONS

The present application is a continuation of U.S. Ser. No. 10/396,179 now U.S. Pat. No. 6,743,437 which is a continuation of U.S. Ser. No. 09/982,219, filed Oct. 17, 2001 now U.S. Pat. No. 6,537,568 which is a continuation of U.S. Ser. No. 09/587,485, filed Jun. 5, 2000 now U.S. Pat. No. 6,306,426 which is a continuation-in-part of U.S. Ser. No. 09/356,074 filed Jul. 16, 1999, now U.S. Pat. No. 6,110,485 which is a continuation of U.S. Ser. No. 09/150,990 filed Sep. 10, 1998, now abandoned which is a continuation of U.S. Ser. No. 08/908,094 filed Aug. 11, 1997, now abandoned.

### FIELD OF THE INVENTION

The invention relates to powdered preparations containing tiotropium for inhalation, processes for preparing them as well as their use for preparing a pharmaceutical composition for treating respiratory complaints, particularly for treating COPD (chronic obstructive pulmonary disease) and asthma.

### BACKGROUND OF THE INVENTION

Tiotropium bromide is known from European Patent Application EP 418 716 A1 and has the following chemical structure:

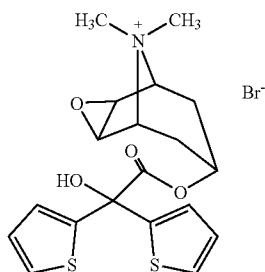

Tiotropium bromide is a highly effective anticholinergic with a long-lasting activity which can be used to treat respiratory complaints, particularly COPD (chronic obstructive pulmonary disease) and asthma. The term tiotropium refers to the free ammonium cation.

For treating the abovementioned complaints, it is useful to administer the active substance by inhalation. In addition to the administration of broncholytically active compounds in the form of metered aerosols and inhalable solutions, the use of inhalable powders containing active substance is of particular importance.

With active substances which have a particularly high efficacy, only small amounts of the active substance are needed per single dose to achieve the desired therapeutic effect. In such cases, the active substance has to be diluted with suitable excipients in order to prepare the inhalable powder. Because of the large amount of excipient, the properties of the inhalable powder are critically influenced by the choice of excipient. When choosing the excipient its particle size is particularly important. As a rule, the finer the excipient, the poorer its flow properties. However, good flow properties are a prerequisite for highly accurate metering when packing and dividing up the individual doses of preparation, e.g. when producing capsules (inhalettes) for powder inhalation or when the patient is metering the

2

individual dose before using a multi-dose inhaler. Moreover, the particle size of the excipient is very important for the emptying characteristics of capsules when used in an inhaler. It has also been found that the particle size of the excipient has a considerable influence on the proportion of active substance in the inhalable powder which is delivered for inhalation. The term inhalable proportion of active substance refers to the particles of the inhalable powder which are conveyed deep into the branches of the lungs when inhaled with a breath. The particle size required for this is between 1 and 10  $\mu\text{m}$ , preferably less than 6  $\mu\text{m}$ .

The aim of the invention is to prepare an inhalable powder containing tiotropium which, while being accurately metered (in terms of the amount of active substance and powder mixture packed into each capsule by the manufacturer as well as the quantity of active substance released and delivered to the lungs from each capsule by the inhalation process) with only slight variations between batches, enables the active substance to be administered in a large inhalable proportion. A further aim of the present invention is to prepare an inhalable powder containing tiotropium which ensures good emptying characteristics of the capsules, whether it is administered to the patient using an inhaler, for example, as described in WO 94/28958, or in vitro using an impactor or impinger.

The fact that tiotropium, particularly tiotropium bromide, has a therapeutic efficacy even at very low doses imposes further conditions on an inhalable powder which is to be used with highly accurate metering. Because only a low concentration of the active substance is needed in the inhalable powder to achieve the therapeutic effect, a high degree of homogeneity of the powder mixture and only slight fluctuations in the dispersion characteristics from one batch of capsules to the next are essential. The homogeneity of the powder mixture and minor fluctuations in the dispersion properties are crucial in ensuring that the inhalable proportion of active substance is released reproducibly in constant amounts and with the lowest possible variability.

Accordingly, a further aim of the present invention is to prepare an inhalable powder containing tiotropium which is characterised by a high degree of homogeneity and uniformity of dispersion. The present invention also sets out to provide an inhalable powder which allows the inhalable proportion of active substance to be administered with the lowest possible variability.

### DETAILED DESCRIPTION OF THE INVENTION

It was found that, surprisingly, the objective outlined above can be achieved by means of the powdered preparations for inhalation (inhalable powders) according to the invention described hereinafter.

Accordingly, the present invention relates to inhalable powders containing 0.04 to 0.8% of tiotropium mixed with a physiologically acceptable excipient, characterised in that the excipient consists of a mixture of coarser excipient with an average particle size of 15 to 80  $\mu\text{m}$  and finer excipient with an average particle size of 1 to 9  $\mu\text{m}$ , the proportion of finer excipient representing 1 to 20% of the total amount of excipient. Inhalable powders which contain 0.08 to 0.64%, most preferably 0.16 to 0.4% of tiotropium, are preferred according to the invention.

By tiotropium is meant the free ammonium cation. The counter-ion (anion) may be chloride, bromide, iodide, methanesulphonate, para-toluenesulphonate or methyl sulphate. Of these anions, the bromide is preferred.

US 7,070,800 B2

3

Accordingly, the present invention preferably relates to inhalable powders which contain between 0.048 and 0.96% of tiotropium bromide. Of particular interest according to the invention are inhalable powders which contain 0.096 to 0.77%, most preferably 0.19 to 0.48% of tiotropium bromide.

The tiotropium bromide which is preferably contained in the inhalable powders according to the invention may include solvent molecules during crystallisation. Preferably, the hydrates of tiotropium bromide, most preferably tiotropium bromide monohydrate, are used to prepare the tiotropium-containing inhalable powder according to the invention. Accordingly the present invention relates to powders for inhalation which contain between 0.05 and 1% of tiotropium bromide monohydrate. Of particular interest according to the invention are inhalable powders which contain 0.1 to 0.8%, most preferably 0.2 to 0.5% of tiotropium bromide monohydrate.

The inhalable powders according to the invention are preferably characterised in that the excipient consists of a mixture of coarser excipient with an average particle size of 17 to 50  $\mu\text{m}$ , most preferably 20 to 30  $\mu\text{m}$ , and finer excipient with an average particle size of 2 to 8  $\mu\text{m}$ , most preferably 3 to 7  $\mu\text{m}$ . The phrase average particle size used here denotes the 50% value from the volume distribution measured with a laser diffractometer using the dry dispersion method. Inhalable powders in which the proportion of finer excipient in the total amount of excipient is from 3 to 15%, most preferably 5 to 10%, are preferred.

The percentages given within the scope of the present invention are always percent by weight.

When reference is made to a mixture within the scope of the present invention, this always means a mixture obtained by mixing together clearly defined components. Accordingly, when an excipient mixture of coarser and finer excipients is mentioned, this can only denote mixtures obtained by mixing a coarser excipient component with a finer excipient component.

The coarser and finer excipient fractions may consist of chemically identical or chemically different substances, while inhalable powders in which the coarser excipient fraction and the finer excipient fraction consist of the same chemical compound are preferred.

Examples of physiologically acceptable excipients which may be used to prepare the inhalable powders according to the invention include, for example, monosaccharides (e.g. glucose or arabinose), disaccharides (e.g. lactose, saccharose, maltose), oligo- and polysaccharides (e.g. dextrane), polyalcohols (e.g. sorbitol, mannitol, xylitol), salts (e.g. sodium chloride, calcium carbonate) or mixtures of these excipients with one another. Preferably, mono- or disaccharides are used, while the use of lactose or glucose is preferred, particularly, but not exclusively, in the form of their hydrates. For the purposes of the invention, lactose is the particularly preferred excipient, while lactose monohydrate is most particularly preferred.

The inhalable powders according to the invention may for example be administered using inhalers which meter a single dose from a reservoir by means of a measuring chamber (e.g. according to U.S. Pat. No. 4,570,630A) or by other means (e.g. according to DE 36 25 685 A). Preferably, however, the inhalable powders according to the invention are packed into capsules (to make so-called inhalettes), which are used in inhalers such as those described in WO 94/28958, for example.

If the inhalable powder according to the invention is to be packed into capsules (inhalettes) in accordance with the

4

preferred application mentioned above, it is advisable to fill the capsules with amounts of from 3 to 10 mg, preferably from 4 to 6 mg of inhalable powder per capsule. These will then contain between 1.2 and 80  $\mu\text{g}$  of tiotropium. With a preferred filling of 4 to 6 mg of inhalable powder per capsule, the content of tiotropium per capsule is between 1.6 and 48  $\mu\text{g}$ , preferably between 3.2 and 38.4  $\mu\text{g}$ , most preferably between 6.4 and 24  $\mu\text{g}$ . A content of 18  $\mu\text{g}$  of tiotropium, for example, corresponds to a content of about 21.7  $\mu\text{g}$  of tiotropium bromide.

Consequently, capsules containing 3 to 10 mg of powder for inhalation preferably hold between 1.4 and 96.3  $\mu\text{g}$  of tiotropium bromide, according to the invention. When the filling is from 4 to 6 mg of inhalable powder per capsule, as is preferred, each capsule contains between 1.9 and 57.8  $\mu\text{g}$ , preferably between 3.9 and 46.2  $\mu\text{g}$ , most preferably between 7.7 and 28.9  $\mu\text{g}$  of tiotropium bromide. A content of 21.7  $\mu\text{g}$  of tiotropium bromide, for example, corresponds to a content of about 22.5  $\mu\text{g}$  of tiotropium bromide monohydrate.

Consequently, capsules containing 3 to 10 mg of powder for inhalation preferably hold between 1.5 and 100  $\mu\text{g}$  of tiotropium bromide monohydrate. When the filling is from 4 to 6 mg of inhalable powder per capsule, as is preferred, each capsule contains between 2 and 60  $\mu\text{g}$ , preferably between 4 and 48  $\mu\text{g}$ , most preferably between 8 and 30  $\mu\text{g}$  of tiotropium bromide monohydrate.

The inhalable powders according to the invention are characterised, in accordance with the objective on which the present invention is based, by a high degree of homogeneity in terms of the accuracy of metering of single doses. This is in the range of <8%, preferably <6%, most preferably <4%.

The inhalable powders according to the invention may be obtained by the method described hereinafter.

After the starting materials have been weighed out, first of all the excipient mixture is prepared from the defined fractions of the coarser excipient and finer excipient. Then the inhalable powder according to the invention is prepared from the excipient mixture and the active substance. If the inhalable powder is to be administered using inhalettes in suitable inhalers, the preparation of the inhalable powders is followed by the manufacture of the powder-filled capsules.

In the preparation processes described hereinafter, the abovementioned components are used in the amounts by weight described in the abovementioned compositions of the inhalable powders according to the invention.

The powders for inhalation according to the invention are prepared by mixing the coarser excipient fractions with the finer excipient fractions and subsequently mixing the resulting excipient mixtures with the active substance.

To prepare the excipient mixture, the coarser and finer excipient fractions are placed in a suitable mixing container. The two components are preferably added using a granulating sieve with a mesh size of 0.1 to 2 mm, preferably 0.3 to 1 mm, most preferably 0.3 to 0.6 mm. Preferably, the coarser excipient is put in first and then the finer excipient fraction is added to the mixing container. During this mixing process the two components are preferably added in batches, with some of the coarser excipient being put in first and then finer and coarser excipient being added alternately. It is particularly preferred when producing the excipient mixture to sieve in the two components in alternate layers. The two components are preferably sieved in alternately in 15 to 45, most preferably 20 to 40 layers each. The mixing of the two excipients may take place while the two components are still being added. Preferably, however, mixing is only done once the two components have been sieved in layer by layer.

## US 7,070,800 B2

5

Once the excipient mixture has been produced, this and the active substance are placed in a suitable mixing container. The active substance used has an average particle size of 0.5 to 10  $\mu\text{m}$ , preferably 1 to 6  $\mu\text{m}$ , most preferably 2 to 5  $\mu\text{m}$ . The two components are preferably added using a granulating sieve with a mesh size of 0.1 to 2 mm, preferably 0.3 to 1 mm, most preferably 0.3 to 0.6 mm. Preferably, the excipient mixture is put in first and then the active substance is added to the mixing container. During this mixing process the two components are preferably added in batches. It is particularly preferred when producing the excipient mixture to sieve in the two components in alternate layers. The two components are preferably sieved in alternately in 25 to 65, most preferably 30 to 60 layers. The mixing of the excipient mixture with the active substance may take place while the two components are still being added. Preferably, however, mixing is only done once the two components have been sieved in layer by layer.

The powder mixture thus obtained may optionally be added once or repeatedly using a granulating sieve and then subjected to another mixing process.

One aspect of the present invention relates to an inhalable powder containing tiotropium, which may be obtained by the methods described hereinbefore.

When the term active substance is used within the scope of the present invention, this is intended as a reference to tiotropium. According to the invention, any reference to tiotropium, which is the free ammonium cation, corresponds to a reference to tiotropium in the form of a salt (tiotropium salt) which contains an anion as the counter-ion. Tiotropium salts which may be used within the scope of the present invention are those compounds which contain chloride, bromide, iodide, methanesulphonate, paratoluenesulphonate or methyl sulphate, in addition to tiotropium as counter-ion (anion). Within the scope of the present invention, tiotropium bromide is preferred of all the tiotropium salts. References to tiotropium bromide within the scope of the present invention should always be taken as references to all possible amorphous and crystalline modifications of tiotropium bromide. These may, for example, include molecules of solvent in their crystalline structure. Of all the crystalline modifications of tiotropium bromide, those which also include water (hydrates) are preferred according to the invention. It is particularly preferable to use tiotropium bromide monohydrate within the scope of the present invention.

In order to prepare the formulations according to the invention, first of all tiotropium has to be prepared in a form which can be used for pharmaceutical purposes. For this, tiotropium bromide, which may be prepared as disclosed in EP 418 716 A1, is preferably subjected to another crystallisation step. Depending on the reaction conditions and solvent used, different crystal modifications are obtained. These modifications may be told apart, for example, by DSC (Differential Scanning Calorimetry).

The following Table summarises the melting points of different crystal modifications of tiotropium bromide depending on the solvent, which are determined by DSC.

solvent	DSC
methanol	228° C.
ethanol	227° C.
ethanol/water	229° C.

6

-continued

solvent	DSC
water	230° C.
isopropanol	229° C.
acetone	225° C.
ethyl acetate	228° C.
tetrahydrofuran	228° C.

Tiotropium bromide monohydrate has proved particularly suitable for preparing the formulation according to the invention. The DSC diagram of tiotropium bromide monohydrate shows two characteristic signals. The first, relatively broad, endothermic signal between 50–120° C. can be attributed to the dehydration of the tiotropium bromide monohydrate to produce the anhydrous form. The second, relatively sharp endothermic peak at 230 $\pm$ 5° C. can be put down to the melting of the substance. These data were obtained using a Mettler DSC 821 and evaluated with the Mettler STAR software package. These data, like the other values given in the above Table, were obtained at a heating rate of 10 K/min.

The following Examples serve to illustrate the present invention further without restricting its scope to the embodiments provided hereinafter by way of example.

## Starting Materials

In the Examples which follow, lactose-monohydrate (200M) is used as the coarser excipient. It may be obtained, for example, from Messrs DMV International, 5460 Veghel/NL under the product name Pharmatose 200M.

In the Examples which follow, lactose-monohydrate (5 $\mu$ ) is used as the finer excipient. It may be obtained from lactose-monohydrate 200M by conventional methods (micronising). Lactose-monohydrate 200M may be obtained, for example, from Messrs DMV International, 5460 Veghel/NL under the product name Pharmatose 200M.

## Preparation of Tiotropium Bromide Monohydrate

15.0 kg of tiotropium bromide are added to 25.7 kg of water in a suitable reaction vessel. The mixture is heated to 80–90° C. and stirred at constant temperature until a clear solution is formed. Activated charcoal (0.8 kg), moistened with water, is suspended in 4.4 kg of water, this mixture is added to the solution containing the tiotropium bromide and rinsed with 4.3 kg of water. The mixture thus obtained is stirred for at least 15 min at 80–90° C. and then filtered through a heated filter into an apparatus which has been preheated to an outer temperature of 70° C. The filter is rinsed with 8.6 kg of water. The contents of the apparatus are cooled at 3–5° C. every 20 minutes to a temperature of 20–25° C. The apparatus is further cooled to 10–15° C. using cold water and crystallisation is completed by stirring for at least one hour. The crystals are isolated using a suction drier, the crystal slurry isolated is washed with 9 liters of cold water (10–15° C.) and cold acetone (10–15° C.). The crystals obtained are dried in a nitrogen current at 25° C. over 2 hours. Yield: 13.4 kg of tiotropium bromide monohydrate (86% of theory).

The crystalline tiotropium bromide monohydrate thus obtained is micronised by known methods, to bring the active substance into the average particle size which meets the specifications according to the invention.

The method of determining the average particle size of the various ingredients of the formulation according to the invention is described as follows.

## US 7,070,800 B2

7

A) Determining the particle size of finely divided lactose:

#### Measuring Equipment and Settings

The equipment is operated according to the manufacturer's instructions.

Measuring equipment:	HELOS Laser-diffraction spectrometer, (SympaTec)
Dispersing unit:	RODOS dry disperser with suction funnel, (SympaTec)
Sample quantity:	from 100 mg
Product feed:	Vibri Vibrating channel, Messrs. Sympatec
Frequency of vibrating channel:	40 rising to 100%
Duration of sample feed:	1 to 15 sec. (in the case of 100 mg)
Focal length:	100 mm (measuring range: 0.9–175 $\mu\text{m}$ )
Measuring time:	about 15 s (in the case of 100 mg)
Cycle time:	20 ms
Start/stop at:	1% on channel 28
Dispersing gas:	compressed air
Pressure:	3 bar
Vacuum:	maximum
Evaluation method:	HRLD

#### Sample Preparation/Product Feed

At least 100 mg of the test substance are weighed onto a piece of card. Using another piece of card all the larger lumps are broken up. The powder is then sprinkled finely over the front half of the vibrating channel (starting about 1 cm from the front edge). After the start of the measurement the frequency of the vibrating channel is varied from about 40% up to 100% (towards the end of the measurement). The time taken to feed in the entire sample is 10 to 15 sec.

B) Determining the particle size of micronised tiotropium bromide monohydrate:

#### Measuring Equipment and Settings

The equipment is operated according to the manufacturer's instructions.

Measuring equipment:	Laser diffraction spectrometer (HELOS), Sympatec
Dispersing unit:	RODOS dry disperser with suction funnel, Sympatec
Sample quantity:	50 mg–400 mg
Product feed:	Vibri Vibrating channel, Messrs. Sympatec
Frequency of vibrating channel:	40 rising to 100%
Duration of sample feed:	15 to 25 sec. (in the case of 200 mg)
Focal length:	100 mm (measuring range: 0.9–175 $\mu\text{m}$ )
Measuring time:	about 15 s (in the case of 200 mg)
Cycle time:	20 ms
Start/stop at:	1% on channel 28
Dispersing gas:	compressed air
Pressure:	3 bar
Vacuum:	maximum
Evaluation method:	HRLD

#### Sample Preparation/Product Feed

About 200 mg of the test substance are weighed onto a piece of card. Using another piece of card all the larger lumps are broken up. The powder is then sprinkled finely over the front half of the vibrating channel (starting about 1 cm from the front edge). After the start of the measurement the frequency of the vibrating channel is varied from about 40% up to 100% (towards the end of the measurement). The

8

sample should be fed in as continuously as possible. However, the amount of product should not be so great that adequate dispersion cannot be achieved. The time over which the entire sample is fed in is about 15 to 25 seconds for 200 mg, for example.

C) Determining the particle size of lactose 200M

#### Measuring Equipment and Settings

The equipment is operated according to the manufacturer's instructions.

Measuring equipment:	Laser diffraction spectrometer (HELOS), Sympatec
Dispersing unit:	RODOS dry disperser with suction funnel, Sympatec
Sample quantity:	500 mg
Product feed:	VIBRI Vibrating channel, Messrs. Sympatec
Frequency of vibrating channel:	18 rising to 100%
Focal length (1):	200 mm (measuring range: 1.8–350 $\mu\text{m}$ )
Focal length (2):	500 mm (measuring range: 4.5–875 $\mu\text{m}$ )
Measuring time:	10 s
Cycle time:	10 ms
Start/stop at:	1% on channel 19
Pressure:	3 bar
Vacuum:	maximum
Evaluation method:	HRLD

#### Sample Preparation/Product Feed

About 500 mg of the test substance are weighed onto a piece of card. Using another piece of card all the larger lumps are broken up. The powder is then transferred into the funnel of the vibrating channel. A gap of 1.2 to 1.4 mm is set between the vibrating channel and funnel. After the start of the measurement the amplitude setting of the vibrating channel is increased from 0 to 40% until a continuous flow of product is obtained. Then it is reduced to an amplitude of about 18%. Towards the end of the measurement the amplitude is increased to 100%.

#### Apparatus

The following machines and equipment, for example, may be used to prepare the inhalable powders according to the invention:

Mixing container or powder mixer: Gyrowheel mixer 200 L; type: DFw80N-4; made by:

Messrs Engelsmann, D-67059 Ludwigshafen.

Granulating sieve: Quadro Comil; type: 197-S; made by: Messrs Joisten & Kettenbaum, D-51429 Bergisch-Gladbach.

#### EXAMPLE 1

##### 1.1: Excipient Mixture

31.82 kg of lactose monohydrate for inhalation (200M) are used as the coarser excipient component. 1.68 kg of lactose monohydrate (5  $\mu\text{m}$ ) are used as the finer excipient component. In the resulting 33.5 kg of excipient mixture the proportion of the finer excipient component is 5%.

About 0.8 to 1.2 kg of lactose monohydrate for inhalation (200M) are added to a suitable mixing container through a suitable granulating sieve with a mesh size of 0.5 mm. Then alternate layers of lactose monohydrate (5  $\mu\text{m}$ ) in batches of about 0.05 to 0.07 kg and lactose monohydrate for inhalation (200M) in batches of 0.8 to 1.2 kg are sieved in. Lactose

## US 7,070,800 B2

9

monohydrate for inhalation (200M) and lactose monohydrate (5  $\mu\text{m}$ ) are added in 31 and 30 layers, respectively (tolerance: $\pm 6$  layers).

The ingredients sieved in are then mixed together (mixing at 900 rpm).

## 1.2: Final Mixture

To prepare the final mixture, 32.87 kg of the excipient mixture (1.1) and 0.13 kg of micronised tiotropium bromide monohydrate are used. The content of active substance in the resulting 33.0 kg of inhalable powder is 0.4%.

About 1.1 to 1.7 kg of excipient mixture (1.1) are added to a suitable mixing container through a suitable granulating sieve with a mesh size of 0.5 mm. Then alternate layers of tiotropium bromide monohydrate in batches of about 0.003 kg and excipient mixture (1.1) in batches of 0.6 to 0.8 kg are sieved in. The excipient mixture and the active substance are added in 46 or 45 layers, respectively (tolerance: $\pm 9$  layers).

The ingredients sieved in are then mixed together (mixing at 900 rpm). The final mixture is passed through a granulating sieve twice more and then mixed (mixing at 900 rpm).

## EXAMPLE 2

Inhalation capsules (inhalettes) having the following composition were produced using the mixture obtained according to Example 1:	
tiotropium bromide monohydrate:	0.0225 mg
lactose monohydrate (200 M):	5.2025 mg
lactose monohydrate (5 $\mu\text{m}$ ):	0.2750 mg
hard gelatine capsule:	49.0 mg
Total:	54.5 mg

## EXAMPLE 3:

Inhalation capsules having the composition:	
tiotropium bromide monohydrate:	0.0225 mg
lactose monohydrate (200 M):	4.9275 mg
lactose monohydrate (5 $\mu\text{m}$ ):	0.5500 mg
hard gelatine capsule:	49.0 mg
Total:	54.5 mg

The inhalable powder needed to prepare the capsules was obtained analogously to Example 1.

## Example 4:

Inhalation capsules having the composition:	
tiotropium bromide monohydrate:	0.0225 mg
lactose monohydrate (200 M):	5.2025 mg
lactose monohydrate (5 $\mu\text{m}$ ):	0.2750 mg
polyethylene capsule:	100.0 mg
Total:	105.50 mg

The inhalable powder needed to prepare the capsules was obtained analogously to Example 1.

For the purposes of the present invention the mean particle size denotes the value in  $\mu\text{m}$  at which 50% of the

10

particles from the volume distribution have a particle size which is smaller than or equal to the value specified. Laser diffraction/dry dispersion is used as the method of measurement for determining the total distribution of the particle size distribution.

We claim:

1. An inhalable powder comprising 0.04 to 0.8% of tiotropium in admixture with a physiologically acceptable excipient, wherein the excipient consists of a mixture of coarser excipient with an average particle size of 15 to 80  $\mu\text{m}$  and finer excipient with an average particle size of 1 to 9  $\mu\text{m}$ , the proportion of the finer excipient constituting 1 to 20% of the total amount of excipient, wherein the inhalable proportion of active substance is released reproducibly in low variability amounts when administered to a patent.

2. An inhalable powder according to claim 1, wherein the tiotropium is present in the form of the chloride, bromide, iodide, methanesulphonate, para-toluenesulphonate or methyl sulphate thereof.

3. An inhalable powder comprising between 0.048 and 0.96% of tiotropium bromide in admixture with a physiologically acceptable excipient, wherein the excipient consists of a mixture of coarser excipient with an average particle size of 15 to 80  $\mu\text{m}$  and finer excipient with an average particle size of 1 to 9  $\mu\text{m}$ , the proportion of the finer excipient constituting 1 to 20% of the total amount of excipient, wherein the inhalable proportion of active substance is released reproducibly in low variability amounts when administered to a patent.

4. An inhalable powder comprising between 0.05 and 1% of tiotropium bromide monohydrate in admixture with a physiologically acceptable excipient, wherein the excipient consists of a mixture of coarser excipient with an average particle size of 15 to 80  $\mu\text{m}$  and finer excipient with an average particle size of 1 to 9  $\mu\text{m}$ , the proportion of the finer excipient constituting 1 to 20% of the total amount of excipient, wherein the inhalable proportion of active substance is released reproducibly in low variability amounts when administered to a patent.

5. An inhalable powder according to one of claims 1, 2, 3 or 4, wherein the excipient consists of a mixture of coarser excipient with an average particle size of 17 to 50  $\mu\text{m}$  and finer excipient with an average particle size of 2 to 8  $\mu\text{m}$ .

6. An inhalable powder according to one of claims 1, 2, 3 or 4, wherein the proportion of finer excipient in the total amount of excipient is 3 to 15%.

7. An inhalable powder according to one of claims 1, 2, 3 or 4, wherein the tiotropium used has an average particle size of 0.5 to 10  $\mu\text{m}$ .

8. An inhalable powder according to one of claims 1, 2, 3 or 4, wherein one or more monosaccharides, disaccharides, oligo- or polysaccharides, polyalcohols, salts thereof, or mixtures thereof are used as the excipients.

9. An inhalable powder according to claim 8, wherein glucose, arabinose, lactose, saccharose, maltose, dextrane, sorbitol, mannitol, xylitol, sodium chloride, calcium carbonate or mixtures thereof are used as the excipients.

10. An inhalable powder according to claim 9, wherein glucose or lactose or mixtures thereof are used as the excipients.

11. A process for preparing an inhalable powder according to one of claims 1 to 4, comprising: (a) mixing coarser excipient fractions with finer excipient fractions to obtain an excipient mixture, and (b) mixing the excipient mixture thus obtained with the tiotropium.

12. A method of treating a disease that is responsive to the administration of tiotropium, comprising administering to a

## US 7,070,800 B2

11

host in need thereof an inhalable powder according to one of claims 1 to 4 or 12.

13. A method according to claim 12, wherein the disease is asthma or COPD.

14. An inhalable powder according to claim 4 comprising 0.1 to 0.8% of tiotropium bromide monohydrate.

15. An inhalable powder according to claim 4 comprising 0.2 to 0.5% of tiotropium bromide monohydrate.

16. An inhalable powder according to one of claim 1, 2, 3 or 4, wherein the excipient consists of a mixture of coarser excipient with an average particle size of 20 to 30  $\mu\text{m}$  and finer excipient with an average particle size of 3 to 7  $\mu\text{m}$ .

17. An inhalable powder according to one of claim 1, 2, 3 or 4, wherein the proportion of finer excipient in the total amount of excipient is 5 to 10%.

18. An inhalable powder according to one of claim 1, 2, 3 or 4, wherein the tiotropium used has an average particle size of 1 to 6  $\mu\text{m}$ .

19. An inhalable powder according to one of claim 1, 2, 3 or 4, wherein the tiotropium used has an average particle size of 2 to 5  $\mu\text{m}$ .

20. An inhalable powder according to claim 10, wherein lactose monohydrate is used as the excipient.

21. An inhalable powder comprising between 0.2 and 0.5% of tiotropium bromide monohydrate in admixture with lactose monohydrate as the physiologically acceptable excipient, wherein the excipient consists of a mixture of coarser excipient with an average particle size of 20 to 30  $\mu\text{m}$  and finer excipient with an average particle size of 3 to 7  $\mu\text{m}$ , the proportion of the finer excipient constituting 5 to 10% of the total amount of excipient, wherein the inhalable proportion of active substance is released reproducibly in low variability amounts when administered to a patent.

22. An inhalable powder comprising 0.04 to 0.8% of tiotropium in admixture with a physiologically acceptable excipient, said inhalable powder prepared by a process comprising: (a) mixing coarser excipient having an average particle size of 15 to 80  $\mu\text{m}$  and finer excipient having an average particle size of 1 to 9  $\mu\text{m}$ , wherein the proportion of the finer excipient constitutes 1 to 20% of the total amount of excipient, to obtain an excipient mixture, and (b) mixing the excipient mixture thus obtained with the tiotropium, wherein the inhalable proportion of active substance is released reproducibly in low variability amounts when administered to a patent.

23. An inhalable powder according to claim 22, wherein the tiotropium is present in the form of the chloride, bromide, iodide, methanesulphonate, paratoluenesulphonate or methyl sulphate thereof.

24. An inhalable powder comprising between 0.048 and 0.96% of tiotropium bromide in admixture with a physiologically acceptable excipient, said inhalable powder prepared by a process comprising: (a) mixing coarser excipient having an average particle size of 15 to 80  $\mu\text{m}$  and finer excipient having an average particle size of 1 to 9  $\mu\text{m}$ , wherein the proportion of the finer excipient constitutes 1 to 20% of the total amount of excipient, to obtain an excipient mixture, and (b) mixing the excipient mixture thus obtained with the tiotropium bromide, wherein the inhalable proportion of active substance is released reproducibly in low variability amounts when administered to a patent.

25. An inhalable powder comprising between 0.05 and 1% of tiotropium bromide monohydrate in admixture with a physiologically acceptable excipient, said inhalable powder prepared by a process comprising: (a) mixing coarser excipient having an average particle size of 15 to 80  $\mu\text{m}$  and finer excipient having an average particle size of 1 to 9  $\mu\text{m}$ , wherein the proportion of the finer excipient constitutes 1 to

12

20% of the total amount of excipient, to obtain an excipient mixture, and (b) mixing the excipient mixture thus obtained with the tiotropium bromide monohydrate, wherein the inhalable proportion of active substance is released reproducibly in low variability amounts when administered to a patent.

26. An inhalable powder according to claim 25 comprising 0.1 to 0.8% of tiotropium bromide monohydrate.

27. An inhalable powder according to claim 25 comprising 0.2 to 0.5% of tiotropium bromide monohydrate.

28. An inhalable powder according to one of claim 22, 23, 24 or 25, wherein the coarser excipient has an average particle size of 17 to 50  $\mu\text{m}$  and the finer excipient has an average particle size of 2 to 8  $\mu\text{m}$ .

29. An inhalable powder according to one of claim 22, 23, 24 or 25, wherein the coarser excipient has an average particle size of 20 to 30  $\mu\text{m}$  and the finer excipient has an average particle size of 3 to 7  $\mu\text{m}$ .

30. An inhalable powder according to one of claim 22, 23, 24 or 25, wherein the proportion of finer excipient in the total amount of excipient is 3 to 15%.

31. An inhalable powder according to one of claim 22, 23, 24 or 25, wherein the proportion of finer excipient in the total amount of excipient is 5 to 10%.

32. An inhalable powder according to one of claim 22, 23, 24 or 25, wherein the tiotropium used has an average particle size of 0.5 to 10  $\mu\text{m}$ .

33. An inhalable powder according to one of claim 22, 23, 24 or 25, wherein the tiotropium used has an average particle size of 1 to 6  $\mu\text{m}$ .

34. An inhalable powder according to one of claim 22, 23, 24 or 25, wherein the tiotropium used has an average particle size of 2 to 5  $\mu\text{m}$ .

35. An inhalable powder according to one of claim 22, 23, 24 or 25, wherein one or more monosaccharides, disaccharides, oligo- or polysaccharides, polyalcohols, salts thereof, or mixtures thereof are used as the excipients.

36. An inhalable powder according to claim 35, wherein glucose, arabinose, lactose, saccharose, maltose, dextrane, sorbitol, mannitol, xylitol, sodium chloride, calcium carbonate or mixtures thereof are used as the excipients.

37. An inhalable powder according to claim 36, wherein glucose or lactose or mixtures thereof are used as the excipients.

38. An inhalable powder according to claim 37, wherein lactose monohydrate is used as the excipient.

39. An inhalable powder comprising between 0.2 and 0.5% of tiotropium bromide monohydrate in admixture with lactose monohydrate as a physiologically acceptable excipient, said inhalable powder prepared by a process comprising: (a) mixing coarser lactose monohydrate excipient having an average particle size of 20 to 30  $\mu\text{m}$  and finer lactose monohydrate excipient having an average particle size of 3 to 7  $\mu\text{m}$ , wherein the proportion of the finer lactose monohydrate excipient constitutes 5 to 10% of the total amount of excipient, to obtain an excipient mixture, and (b) mixing the excipient mixture thus obtained with the tiotropium bromide monohydrate, wherein the inhalable proportion of active substance is released reproducibly in low variability amounts when administered to a patent.

40. A method of treating a disease that is responsive to the administration of tiotropium, comprising administering to a host in need thereof an inhalable powder according to one of claim 22, 23, 24 or 25 or 39.

41. A method according to claim 40, wherein the disease is asthma or COPD.

\* \* \* \* \*

UNITED STATES PATENT AND TRADEMARK OFFICE  
**CERTIFICATE OF CORRECTION**

PATENT NO. : 7,070,800 B2  
APPLICATION NO. : 09/975418  
DATED : July 4, 2006  
INVENTOR(S) : Karoline Bechtold-Peters et al.

Page 1 of 1

It is certified that error appears in the above-identified patent and that said Letters Patent is hereby corrected as shown below:

In column 10, line 15 delete "patent" and replace with --patient--.

Signed and Sealed this

Eighth Day of August, 2006

A handwritten signature in black ink on a light gray dotted background. The signature reads "Jon W. Dudas" in a cursive style.

JON W. DUDAS

*Director of the United States Patent and Trademark Office*

UNITED STATES PATENT AND TRADEMARK OFFICE  
**CERTIFICATE OF CORRECTION**

PATENT NO. : 7,070,800 B2  
APPLICATION NO. : 09/975418  
DATED : July 4, 2006  
INVENTOR(S) : Karin Bechtold Peters et al.

Page 1 of 1

It is certified that error appears in the above-identified patent and that said Letters Patent is hereby corrected as shown below:

In column 10, line 29, delete “patent” and replace with --patient--

In column 10, line 39, delete “patent” and replace with --patient--

In column 11, line 32, delete “patent” and replace with --patient--

In column 11, line 43, delete “patent” and replace with --patient--

In column 11, line 58, delete “patent” and replace with --patient--

In column 12, line 6, delete “patent” and replace with --patient--

In column 12, line 57, delete “patent” and replace with --patient--

Signed and Sealed this

Twelfth Day of August, 2008

A handwritten signature in black ink that reads "Jon W. Dudas". The signature is written in a cursive style with a large, stylized initial 'J'.

JON W. DUDAS  
*Director of the United States Patent and Trademark Office*



# EXHIBIT C



US007694676B2

(12) **United States Patent**  
**Wachtel**

(10) **Patent No.:** **US 7,694,676 B2**  
(45) **Date of Patent:** **Apr. 13, 2010**

(54) **DRY POWDER INHALER**  
(75) Inventor: **Herbert Wachtel**, Ingelheim (DE)  
(73) Assignee: **Boehringer Ingelheim GmbH**,  
Ingelheim am Rhein (DE)  
(\* ) Notice: Subject to any disclaimer, the term of this  
patent is extended or adjusted under 35  
U.S.C. 154(b) by 689 days.

6,055,980 A \* 5/2000 Mecikalski et al. .... 128/203.15  
6,182,655 B1 \* 2/2001 Keller et al. .... 128/203.15  
6,273,084 B1 \* 8/2001 Frid ..... 128/200.23  
6,273,085 B1 \* 8/2001 Eisele et al. .... 128/203.15  
6,328,034 B1 \* 12/2001 Eisele et al. .... 128/203.15  
6,367,473 B1 \* 4/2002 Kafer ..... 128/203.21  
7,252,087 B2 \* 8/2007 Wachtel ..... 128/203.21  
2003/0070679 A1 4/2003 Hochrainer et al.  
2004/0094146 A1 \* 5/2004 Schiewe et al. .... 128/200.11  
2007/0221211 A1 \* 9/2007 Sagalovich ..... 128/200.15

FOREIGN PATENT DOCUMENTS

(21) Appl. No.: **11/113,091**  
(22) Filed: **Apr. 22, 2005**

SU 1733008 A1 11/1989  
WO 02-098874 A2 12/2002  
WO WO 03/084502 A1 \* 10/2003

(65) **Prior Publication Data**  
US 2006/0237016 A1 Oct. 26, 2006

\* cited by examiner

(51) **Int. Cl.**  
**A61M 15/00** (2006.01)  
**A61M 16/00** (2006.01)

*Primary Examiner*—Steven O Douglas  
*Assistant Examiner*—Annette F Dixon  
(74) *Attorney, Agent, or Firm*—Michael P. Morris;  
Mary-Ellen M. Devlin; David L. Kershner

(52) **U.S. Cl.** ..... **128/203.21**; 128/203.15  
(58) **Field of Classification Search** ..... 128/200.24,  
128/203.15, 203.14, 203.19, 203.21; 222/80,  
222/153.1, 189.06, 472; 206/528, 532, 531,  
206/530, 534

(57) **ABSTRACT**

See application file for complete search history.

An inhaler for inhaling powdered pharmaceutical compositions from capsules includes: a lower part; a plate which can be latched to the lower part and with which the lower part can be closed off; a capsule holder for receiving the capsules, this holder being adapted to be lowered into the lower part; a mouthpiece latchable to the plate; a lid which covers the mouthpiece in a closed position and latches it by means of a closure element, the lower part, the plate, the mouthpiece and the lid being hinged together by means of a single joint; and an actuating member which can be moved out a resting position and thereby interacts with at least one pin which can be made to pierce the capsule holder.

(56) **References Cited**  
U.S. PATENT DOCUMENTS

3,724,459 A \* 4/1973 Congro ..... 128/203.22  
4,860,740 A \* 8/1989 Kirk et al. .... 128/203.15  
5,575,280 A \* 11/1996 Gupte et al. .... 128/203.15  
5,685,294 A \* 11/1997 Gupte et al. .... 128/203.15  
5,685,894 A 11/1997 Bowerman et al.  
5,787,881 A \* 8/1998 Chawla ..... 128/203.15  
5,947,118 A \* 9/1999 Hochrainer et al. .... 128/203.15

**16 Claims, 3 Drawing Sheets**

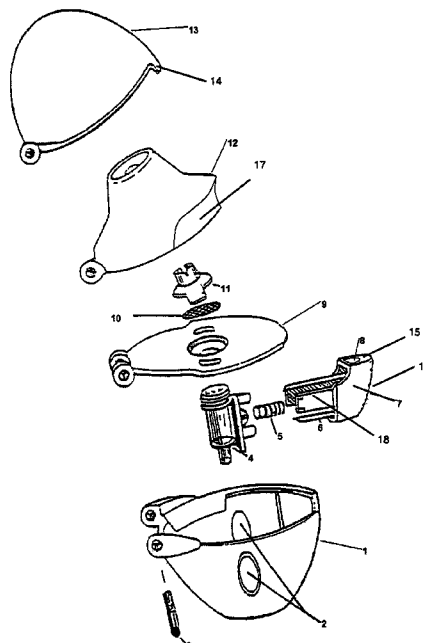

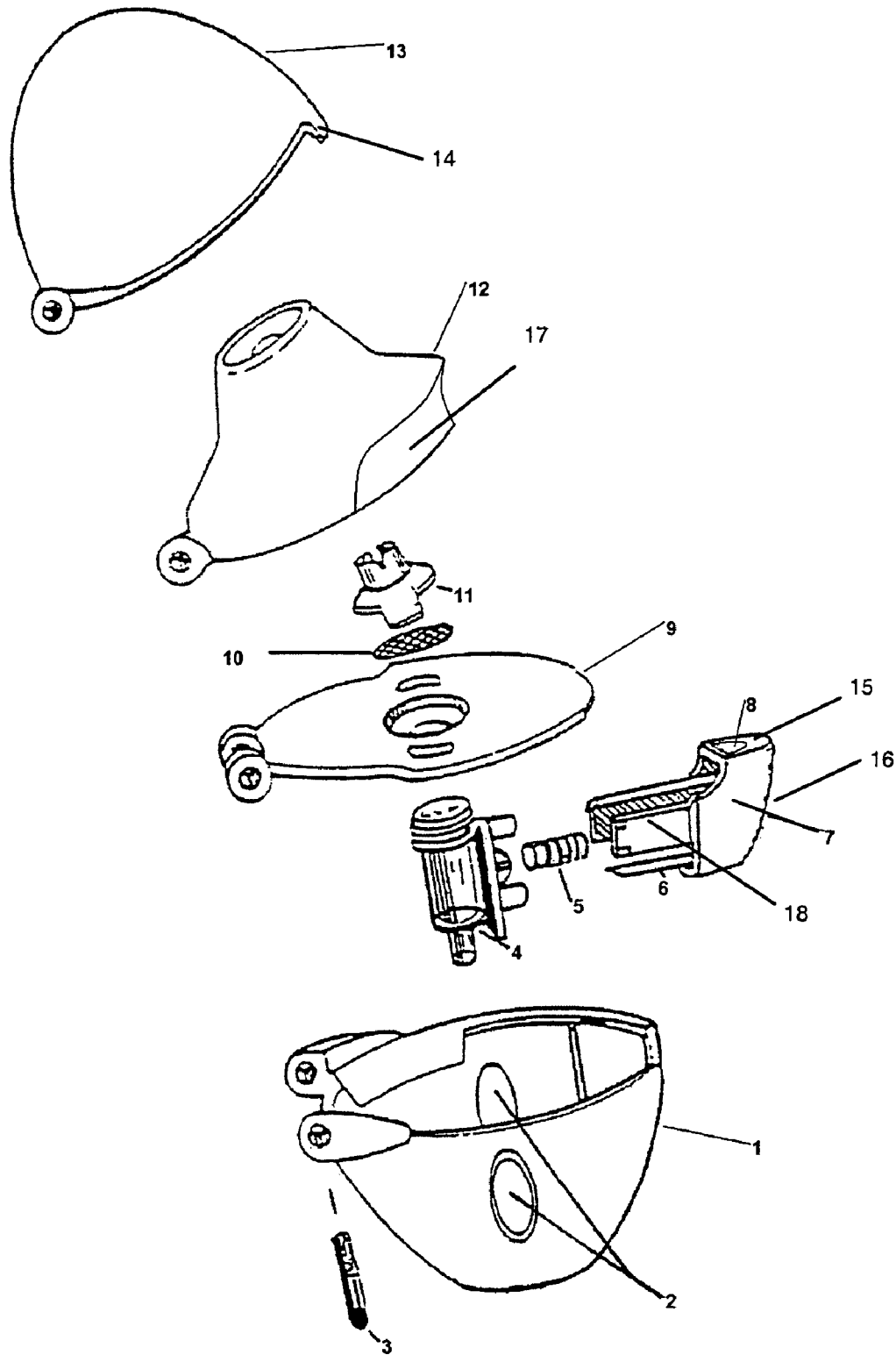
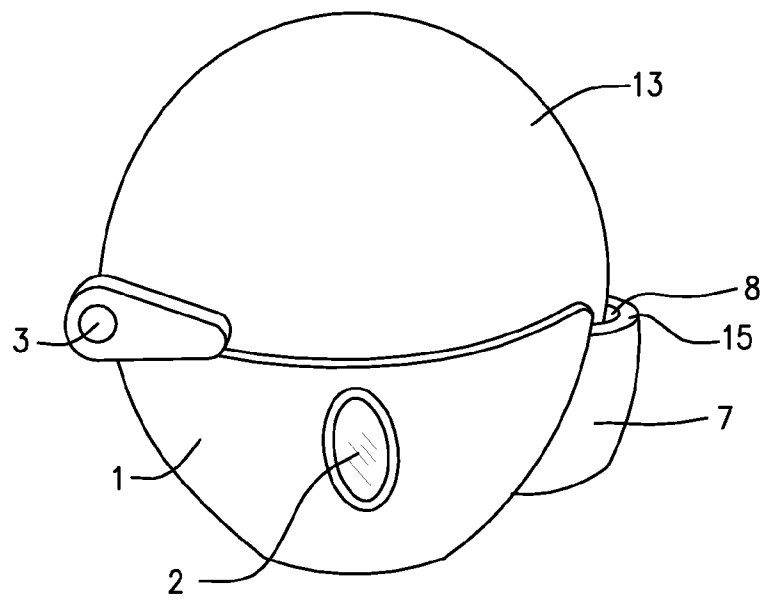

Fig. 1



**FIG. 2**

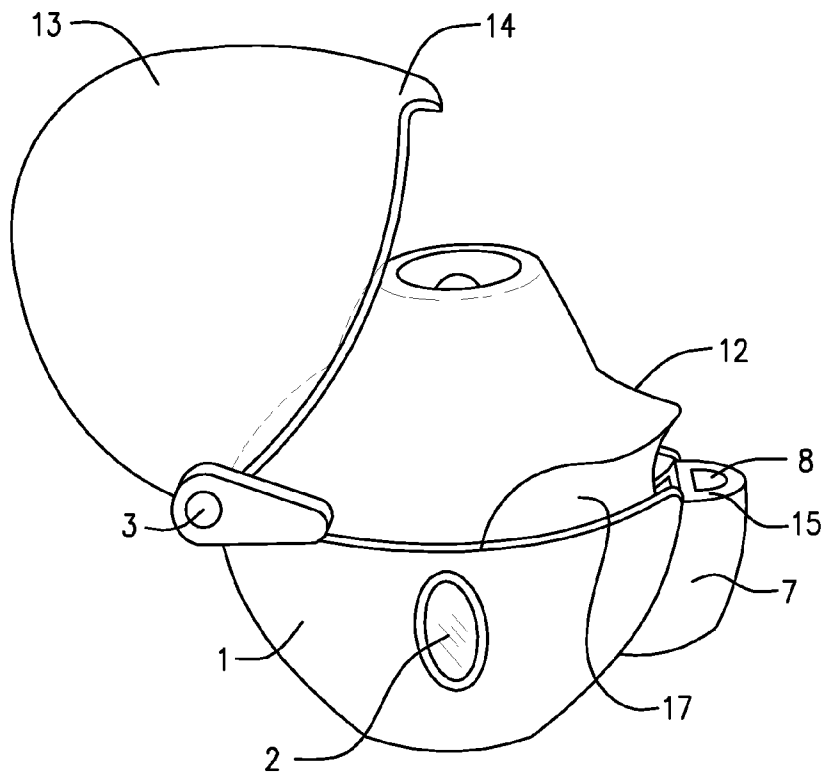

FIG. 3

US 7,694,676 B2

1

**DRY POWDER INHALER**

## BACKGROUND

The invention relates to an inhaler for inhaling powdered pharmaceutical compositions from capsules which are inserted in a capsule holder provided in the inhaler before use. After the capsule has been inserted in the capsule holder the patient can press an actuating member which can be moved out of a resting position, thereby cooperating with at least one pin which can stick into the capsule holder. The capsule is pierced by the minimum of one pin and the pharmaceutical composition is released.

An inhaler of this kind is described for example in EP 0703800 B1 or EP 0911047 A1. The inhaler known from the above mentioned specifications has a dish-shaped lower part and an equally dish-shaped lid which fits it, these two parts being capable of being flipped apart for use, about a joint provided in the edge portion. Between the lower part and the lid, a mouthpiece which can also be flipped open and a plate below it with a capsule holder provided underneath also act on the joint. After the individual assemblies have been flipped open the patient can insert a drug-filled capsule in the capsule holder, pivot the plate and capsule holder and the mouthpiece into the lower part and pierce the capsule by means of a spring loaded actuating member projecting laterally from the lower part. The patient being treated then draws the pharmaceutical composition into his airway by sucking on the mouthpiece.

The intention is to improve the known inhalers still further in terms of their handling.

## SUMMARY OF THE INVENTION

This aim is achieved according to the invention with an inhaler according to a first embodiment, wherein the actuating member is constructed as a double function actuating member by means of which, in a first actuation, the closure element for pivoting the lid can be detached from the lower part, and by means of which, in a second actuation, the procedure for piercing the capsule as described above can be carried out.

An advantage of the invention is that the forces needed to release the lid from the mechanical latching are not introduced directly through the lid but instead through the double function actuating member. This ensures quick and reliable opening of the lid with a clockwork-type mechanism, to make the inhaler ready for use.

In order to allow the lid to be released from the lower part by a clockwork-type mechanism, the double function actuating member has on its upper side a recess which is inclined so as to form a sliding surface for the closure element in the form of a tilting plane and to release the lid from the lower part as the double function actuating member is actuated and hence moved forward. The recess may vary in size. The minimum size must be sufficient to enable the lid to be released from the lower part by a clockwork type mechanism. The maximum size depends on the upper surface of the double function actuating member. The actual opening movement of the lid can then be carried out as previously by actuation of the lid by the patient, opening it fully.

The mouthpiece, which can also be flipped aside, is provided according to the invention with a gripping aid which ensures quick and reliable opening of the mouthpiece. The gripping aid is arranged so that the contact with the mouthpiece is outside the area of the mouthpiece which the patient has to place in his mouth when sucking. The contact surface for opening and the contact surface for sucking are clearly

2

separated from one another thanks to the shape and appearance of the mouthpiece. Consequently, the mouthpiece has an appearance which is improved both optically and practically, which enables the user to handle it intuitively and at the same time ensures optimum hygiene. This is particularly important in the region of the mouthpiece as this component is placed in the mouth when the inhaler is used.

The clockwork-like opening mechanism for the lid according to the invention and the gripping aid on the mouthpiece according to the invention are of great importance, particularly at the start of an asthma attack, as they provide a secure grip and an effective arrangement for patients who would otherwise find it difficult to use the inhaler, possibly because they were suffering from arthritis or had some other restriction to the mobility of their fingers.

In a preferred embodiment, in addition to the spring element between the double function actuating member and the capsule holder for assisting the return of the double function actuating member, at least one other spring element may be provided between the plate and lower part, to assist the opening movement, this additional spring element allowing the lid and/or the mouthpiece to spring open, if the dimensions are suitably selected, thereby completing the clockwork-like opening mechanism.

Preferably, the double function actuating member is movably mounted on the plate or on the capsule holder. The plate and/or capsule holder thus form or forms an abutment for the double function actuating member which slides along the plate when moved from the resting position into the functional position and is guided thereby, for example by means of a guide rail.

In a favourable embodiment, the double function actuating member is spring-loaded. The restoring force which is present even in the resting position ensures that after the double function actuating member has been used it is returned to the resting position and thus the inhaling process can be started or continued.

Advantageously, the double function actuating member comprises a main body and two parallel guide arms engaging thereon. The guide arms project into the lower part and, together with corresponding inserts, e.g. with guide sleeves provided on the outside of the capsule holder, serve to guide the double function actuating member as it moves from the resting position into the various operating positions and back to the resting position.

The guide arms may have end stops at their end remote from the main body, these end stops abutting on the guide sleeves in the resting position. This creates a spring bias on the double function actuating member.

In a preferred embodiment the main body of the double function actuating member has an upper rifled surface and at least one lateral rifled surface. These rifled surfaces are both design elements and help to provide optimum grip during actuation. They are on the main body of the double function actuating member outside the inhalation area and consequently do not come into contact with the patient's mouth area. Moreover, the rifled surfaces may be smaller in area than the rifling of the overall surface and still provide a guarantee of safe and rapid use of the inhaler.

Expediently, the upper rifle surface in the resting position is formed, in its area nearest the lid, with a recess to accommodate the closure element of the lid. Inside the recess the side wall directed towards the lateral rifled surface is inclined so that when the main body is inserted it forms a sliding surface for the closure element and in this way the closure element together with the lid is raised out of the latched position.

## US 7,694,676 B2

3

Advantageously, the plate latched to the lower part can be detached from the lower part such that the plate can be swivelled away from the lower part. This swivel function makes the inhaler easier to clean. The latching between the plate and lower part can be achieved by means of projecting retaining lugs.

It is also possible to construct all the embodiments of the inhaler such that the double function actuating member with the minimum of one pin that can be stuck into the capsule holder is attached to the plate so that it can be detached from the lower part and swung away, together with the plate latched to the lower part.

Other aspects, features, and advantages of the present invention will be apparent to one skilled in the art from the description herein taken in conjunction with the accompanying drawings.

## BRIEF DESCRIPTION OF THE DRAWINGS

To make the invention easier to understand it will now be described more fully with reference to the drawing that follows (FIG. 1).

FIG. 1 shows an exploded view with a double function actuating member and mouthpiece with gripping aid.

## DETAILED DESCRIPTION OF THE PRESENT INVENTION

FIG. 1 shows the inhaler in exploded view. The essential components are the lower part 1 which accommodates the plate 9 and is covered by the latter, the mouthpiece 12 with gripping aid 17, said mouthpiece being latchable to the lower part 1 by means of the retaining lugs of the screen holder 11 and the lid 13 which is shaped so as to complement the lower part 1.

In the closed state of the inhaler the closure element 14 on the lid 13 acts on the plate 9 and is held there by frictional engagement. It is also possible to achieve interlocking engagement by the provision of bead-like structures on the closure element 14. For the closure element 14 on the lid 13 to act on the plate 9, the main body of the double function actuating member 7 comprises a recess 8 into which the closure element 14 is lowered as it closes. The recess 8 has an inclined side wall and is located in the area of the upper rifled surface 15 nearest the lid. For particularly reliable operation the double function actuating member 7 is also provided with at least one lateral rifled surface 16.

In order to open the lid 13, first of all the double function actuating member 7 is moved or pressed towards the inhaler. The closure element 14 on the lid 13 makes contact with the inclined side wall of the recess 8 which acts a sliding surface as the main body 7 continues to move forward, and releases the lid 13.

The lower part 1 is cup-shaped and accommodates the entire capsule holder 4 which is mounted on the underside of the plate 9. In order to be able to place a drug filled capsule (not shown) in the capsule holder 4, the mouthpiece 12 also has to be flipped open. In the embodiment shown in FIG. 1 this is done by acting on the gripping aid 17 shown. The gripping aid 17 is preferably implemented by way of a recess, representing a discontinuity in the otherwise smoothly flowing contour of the outside surface of the mouthpiece 12. The recess of the gripping aid 17 may be disposed at a peripheral edge of the mouthpiece 12 near to where the mouthpiece 12 and the plate 9 come into engagement. The specific contour of the recess of the gripping aid may take on many forms, however, it is preferred that the recess easily and comfortably

4

accommodate a user's fingertip(s) so that adequate leverage may be obtained in order to pivot the mouthpiece 12 away from the plate 9 and lower part 1. The recess of the gripping aid 17 preferably initiates at least one lateral side (preferably both lateral sides) of the mouthpiece 12 and extends toward the actuator 7. The discontinuity (or separation) from the smooth contour of the mouthpiece forms a projection at an upper edge of the recess as the contour tapers toward the peripheral edge of the mouthpiece. One of more of the above features enables a user to pivot the mouthpiece 12 away from the plate 9 and lower part 1 without requiring the user to grip the part of the mouthpiece 12 that touches the user's lips, thereby improving the cleanliness of the mouthpiece 12.

In this opened position of the lid 13 and mouthpiece 12 the capsule can be placed in the capsule holder 4 through an opening in the plate 9. Then the mouthpiece 12 is swivelled back again and closed again by the latching of the retaining lugs of the screen holder 11 in the plate 9. In order to release the active substance, at least one pin, but preferably two perpendicularly offset, parallel pins 6 are mounted on the main body of the double function actuating member 7, moving continuously towards the capsule (not shown) as the double function actuating member 7 is pushed in, so as to perforate said capsule. The perforating process can be observed through an inspection window 2.

In the capsule holder 4 there is one or at least two tubular pin guides which is or are directed axially in accordance with the direction of movement of the pin or pins 6. This ensures accurate targeting of the pin or pins on the capsule (not shown) and also provides additional guiding for the double function actuating member 7. However, the essential guiding is achieved by means of two laterally mounted guide arms 18. The guide arms 18 also have the task of holding the double function actuating member 7 under pre-tension. For this, the guide arms 18 are provided, at their ends remote from the main body, with end stops which abut on the guide sleeves of the capsule holder 4 in the resting position of the double function actuating member 7. The guide sleeves are provided on the outside of the capsule holder 4. Between the guide arms 18 is a helical spring 5 which in the axial direction extends parallel to the pin or pins 6, the helical spring 5 being matched to the length of the guide arms 18 such that the double function actuating member 7 is still biased in the resting position.

The individual assemblies of lower part 1, plate 9, mouthpiece 12 and lid 13 are joined together by means of joint sockets and a joint bolt 3 and are all movable or pivotable about this bolt, relative to one another.

The pharmaceutical compositions used for inhalation may be all of kinds of powdered pharmaceuticals which it is therapeutically advisable to administer by inhalation.

Particularly preferred in this context are pharmaceutical compositions selected from among the anticholinergics, beta-2-agonists, steroids, PDE IV-inhibitors, LTD4-antagonists and EGFR-kinase inhibitors.

Anticholinergics for use are preferably selected from among tiotropium bromide, oxitropium bromide, flutropium bromide, ipratropium bromide, glycopyrronium salts, tropium chloride, tolterodine, tropenol 2,2-diphenylpropionate methobromide, scopine 2,2-diphenylpropionate methobromide, scopine 2-fluoro-2,2-diphenylacetate methobromide, tropenol 2-fluoro-2,2-diphenylacetate methobromide, tropenol 3,3',4,4'-tetrafluorobenzilate methobromide, scopine 3,3',4,4'-tetrafluorobenzilate methobromide, tropenol 4,4'-difluorobenzilate methobromide, scopine 4,4'-difluorobenzilate methobromide, tropenol 3,3'-difluorobenzilate methobromide, scopine 3,3'-difluorobenzilate methobromide, tropenol

## US 7,694,676 B2

5

9-hydroxy-fluorene-9-carboxylate methobromide, tropenol 9-fluoro-fluorene-9-carboxylate methobromide, scopine 9-hydroxy-fluorene-9-carboxylate methobromide, scopine 9-fluoro-fluorene-9-carboxylate methobromide, tropenol 9-methyl-fluorene-9-carboxylate methobromide, scopine 9-methyl-fluorene-9-carboxylate methobromide, cyclopropyltropine benzilate methobromide, 2,2-diphenylpropionate cyclopropyltropine methobromide, cyclopropyltropine 9-hydroxy-xanthene-9-carboxylate methobromide, cyclopropyltropine 9-methyl-fluorene-9-carboxylate methobromide, cyclopropyltropine 9-methyl-xanthene-9-carboxylate methobromide, cyclopropyltropine 9-hydroxy-fluorene-9-carboxylate methobromide, methyl 4,4'-difluorobenzilate cyclopropyltropine methobromide, tropenol 9-hydroxy-xanthene-9-carboxylate methobromide, scopine 9-hydroxy-xanthene-9-carboxylate methobromide, tropenol 9-methyl-xanthene-9-carboxylate methobromide, scopine 9-methyl-xanthene-9-carboxylate methobromide, tropenol 9-ethyl-xanthene-9-carboxylate methobromide, tropenol 9-difluoromethyl-xanthene-9-carboxylate methobromide and scopine 9-hydroxymethyl-xanthene-9-carboxylate methobromide, optionally in the form of the racemates, enantiomers or diastereomers thereof and optionally in the form of the solvates and/or hydrates thereof.

Beta-2-agonists used are preferably selected from among albuterol, bambuterol, bitolterol, broxaterol, carbuterol, clenbuterol, fenoterol, formoterol, hexoprenaline, ibuterol, isoetharine, isoprenaline, levosalbutamol, mabuterol, meluadrine, metaproterenol, orciprenaline, pirbuterol, procaterol, reproterol, rimiterol, ritodrine, salmeterol, salmefamol, soterenol, sulphoterol, tiaramide, terbutaline, tolbuterol, CHF-1035, HOKU-81, KUL-1248, 3-(4-{6-[2-hydroxy-2-(4-hydroxy-3-hydroxymethyl-phenyl)-ethylamino]-hexyloxy}-butyl)-benzenesulphonamide, 5-[2-(5,6-diethyl-indan-2-ylamino)-1-hydroxy-ethyl]-8-hydroxy-1H-quinolin-2-one, 4-hydroxy-7-[2-{[3-(2-phenylethoxy)propyl]sulphonyl}ethyl]-aminoethyl]-2(3H)-benzothiazolone, 1-(2-fluoro-4-hydroxyphenyl)-2-[4-(1-benzimidazolyl)-2-methyl-2-butylamino]ethanol, 1-[3-(4-methoxybenzylamino)-4-hydroxyphenyl]-2-[4-(1-benzimidazolyl)-2-methyl-2-butylamino]ethanol, 1-[2H-5-hydroxy-3-oxo-4H-1,4-benzoxazin-8-yl]-2-[3-(4-N,N-dimethylaminophenyl)-2-methyl-2-propylamino]ethanol, 1-[2H-5-hydroxy-3-oxo-4H-1,4-benzoxazin-8-yl]-2-[3-(4-methoxyphenyl)-2-methyl-2-propylamino]ethanol, 1-[2H-5-hydroxy-3-oxo-4H-1,4-benzoxazin-8-yl]-2-[3-(4-n-butylloxyphenyl)-2-methyl-2-propylamino]ethanol, 1-[2H-5-hydroxy-3-oxo-4H-1,4-benzoxazin-8-yl]-2-{4-[3-(4-methoxyphenyl)-1,2,4-triazol-3-yl]-2-methyl-2-butylamino}ethanol, 5-hydroxy-8-(1-hydroxy-2-isopropylaminobutyl)-2H-1,4-benzoxazin-3-(4H)-one, 1-(4-amino-3-chloro-5-trifluoromethylphenyl)-2-tert.-butylaminoethanol and 1-(4-ethoxycarbonylamino-3-cyano-5-fluorophenyl)-2-(tert.-butylamino)ethanol, optionally in the form of the racemates, enantiomers or diastereomers thereof and optionally in the form of their pharmacologically acceptable acid addition salts, solvates and/or hydrates thereof.

The steroids used are preferably selected from among prednisolone, prednisone, butixocortpropionate, RPR-106541, flunisolide, beclomethasone, triamcinolone, budesonide, fluticasone, mometasone, ciclesonide, rofleponide, ST-126, dexamethasone, (S)-fluoromethyl-6,9-difluoro-17-[(2-furanylcarbonyloxy)-11-hydroxy-16-methyl-3-oxo-androsta-1,4-diene-17-carbothionate, (S)-(2-oxo-tetrahydro-furan-3S-yl) 6,9-difluoro-11-hydroxy-16-methyl-3-oxo-17-propionyloxy-androsta-1,4-diene-17-carbothionate and etiprednol-dichloroacetate (BNP-

6

166), optionally in the form of the racemates, enantiomers or diastereomers thereof and optionally in the form of the salts and derivatives thereof, the solvates and/or hydrates thereof.

PDE IV inhibitors used are preferably selected from among enprofyllin, theophyllin, roflumilast, ariflo (cilomilast), CP-325,366, BY343, D-4396 (Sch-351591), AWD-12-281 (GW-842470), N-(3,5-dichloro-1-oxo-pyridin-4-yl)-4-difluoromethoxy-3-cyclopropylmethoxybenzamide, NCS-613, pumafentine, (-)-p-[(4aR\*,10bS\*)-9-ethoxy-1,2,3,4,4a,10b-hexahydro-8-methoxy-2-methylbenzo[s][1,6]naphthyridin-6-yl]-N,N-diisopropylbenzamide, (R)-(+)-1-(4-bromobenzyl)-4-[(3-cyclopentylloxy)-4-methoxyphenyl]-2-pyrrolidone, 3-(cyclopentylloxy-4-methoxyphenyl)-1-(4-N'-[N-2-cyano-S-methyl-isothioureido]benzyl)-2-pyrrolidone, cis[4-cyano-4-(3-cyclopentylloxy-4-methoxyphenyl)cyclohexane-1-carboxylic acid], 2-carbomethoxy-4-cyano-4-(3-cyclopropylmethoxy-4-difluoromethoxyphenyl)cyclohexan-1-one, cis[4-cyano-4-(3-cyclopropylmethoxy-4-difluoromethoxyphenyl)cyclohexan-1-ol], (R)-(+)-ethyl[4-(3-cyclopentylloxy-4-methoxyphenyl)pyrrolidin-2-ylidene]acetate, (S)-(-)-ethyl[4-(3-cyclopentylloxy-4-methoxyphenyl)pyrrolidin-2-ylidene]acetate, CDP840, Bay-198004, D-4418, PD-168787, T-440, T-2585, arofyllin, atizoram, V-11294A, CI-1018, CDC-801, CDC-3052, D-22888, YM-58997, Z-15370, 9-cyclopentyl-5,6-dihydro-7-ethyl-3-(2-thienyl)-9H-pyrazolo[3,4-c]-1,2,4-triazolo[4,3-a]pyridine and 9-cyclopentyl-5,6-dihydro-7-ethyl-3-(tert-butyl)-9H-pyrazolo[3,4-c]-1,2,4-triazolo[4,3-a]pyridine, optionally in the form of the racemates, enantiomers or diastereomers thereof and optionally in the form of the pharmacologically acceptable acid addition salts thereof, solvates and/or hydrates thereof.

LTD4-antagonists used are preferably selected from among montelukast, 1-(((R)-3-(2-(6,7-difluoro-2-quinolinyl)ethenyl)phenyl)-3-(2-(2-hydroxy-2-propyl)phenyl)thio)methylcyclopropane-acetic acid, 1-(((R)-3-(3-(2-(2,3-dichlorothiophen[3,2-b]pyridin-5-yl)-(E)-ethenyl)phenyl)-3-(2-(1-hydroxy-1-methylethyl)phenyl)propyl)thio)methyl)cyclopropanoic acid, pranlukast, zafirlukast, [2-[[2-(4-tert-butyl-2-thiazolyl)-5-benzofuranyl]oxymethyl]phenyl]acetic acid, MCC-847 (ZD-3523), MN-001, MEN-91507 (LM-1507), VUF-5078, VUF-K-8707 and L-733321, optionally in the form of the racemates, enantiomers or diastereomers thereof, optionally in the form of the pharmacologically acceptable acid addition salts thereof as well as optionally in the form of the salts and derivatives thereof, the solvates and/or hydrates thereof.

EGFR-kinase inhibitors used are preferably selected from among cetuximab, trastuzumab, ABX-EGF, Mab ICR-62, 4-[(3-chloro-4-fluorophenyl)amino]-6-[[4-(morpholin-4-yl)-1-oxo-2-buten-1-yl]amino]-7-cyclopropylmethoxyquinazoline, 4-[(R)-(1-phenyl-ethyl)amino]-6-[[4-(morpholin-4-yl)-1-oxo-2-buten-1-yl]-amino]-7-cyclopentylloxyquinazoline, 4-[(3-chloro-4-fluoro-phenyl)amino]-6-[[4-((R)-6-methyl-2-oxo-morpholin-4-yl)-1-oxo-2-buten-1-yl]amino]-7-[(S)-(tetrahydrofuran-3-yl)oxy]-quinazoline, 4-[(3-chloro-4-fluoro-phenyl)amino]-6-[2-((S)-6-methyl-2-oxo-morpholin-4-yl)-ethoxy]-7-methoxyquinazoline, 4-[(3-chloro-4-fluorophenyl)amino]-6-((4-[N-(2-methoxyethyl)-N-methyl-amino]-1-oxo-2-buten-1-yl)amino)-7-cyclopropylmethoxyquinazoline, 4-[(R)-(1-phenyl-ethyl)amino]-6-((4-[N-(tetrahydropyran-4-yl)-N-methyl-amino]-1-oxo-2-buten-1-yl)amino)-7-cyclopropylmethoxyquinazoline, 4-[(3-chloro-4-fluorophenyl)amino]-6-((4-[N-(2-methoxy-ethyl)-N-methyl-amino]-1-oxo-2-buten-1-yl)amino)-7-cyclopentylloxyquinazoline, 4-[(3-chloro-4-fluorophenyl)amino]-6-[[4-(N,N-dimethylamino)-1-oxo-2-



## US 7,694,676 B2

7

buten-1-yl]amino}-7-[(R)-(tetrahydrofuran-2-yl)methoxy]-quinazoline, 4-[(3-ethynyl-phenyl)amino]-6,7-bis-(2-methoxy-ethoxy)-quinazoline, 4-[(R)-(1-phenyl-ethyl)amino]-6-(4-hydroxy-phenyl)-7H-pyrrolo[2,3-d]pyrimidine, 3-cyano-4-[(3-chloro-4-fluorophenyl)amino]-6-[[4-(N,N-dimethylamino)-1-oxo-2-buten-1-yl]amino]-7-ethoxy-quinoline, 4-[(R)-(1-phenyl-ethyl)amino]-6-[[4-(R)-6-methyl-2-oxo-morpholin-4-yl]-1-oxo-2-buten-1-yl]amino]-7-methoxy-quinazoline, 4-[(3-chloro-4-fluorophenyl)amino]-6-[[4-(morpholin-4-yl)-1-oxo-2-buten-1-yl]amino]-7-[(tetrahydrofuran-2-yl)methoxy]-quinazoline, 4-[(3-ethynyl-phenyl)amino]-6-[[4-(5,5-dimethyl-2-oxo-morpholin-4-yl)-1-oxo-2-buten-1-yl]amino]-quinazoline, 4-[(3-chloro-4-fluoro-phenyl)amino]-6-[[2-[4-(2-oxo-morpholin-4-yl)-piperidin-1-yl]-ethoxy]-7-methoxy-quinazoline, 4-[(3-chloro-4-fluoro-phenyl)amino]-6-(trans-4-amino-cyclohexan-1-yloxy)-7-methoxy-quinazoline, 4-[(3-chloro-4-fluoro-phenyl)amino]-6-(trans-4-methanesulphonylamino-cyclohexan-1-yloxy)-7-methoxy-quinazoline, 4-[(3-chloro-4-fluoro-phenyl)amino]-6-(tetrahydropyran-3-yloxy)-7-methoxy-quinazoline, 4-[(3-chloro-4-fluoro-phenyl)amino]-6-[[1-(morpholin-4-yl)carbonyl]-piperidin-4-yloxy]-7-methoxy-quinazoline, 4-[(3-chloro-4-fluoro-phenyl)amino]-6-(piperidin-3-yloxy)-7-methoxy-quinazoline, 4-[(3-chloro-4-fluoro-phenyl)amino]-6-[[1-(2-acetylamino-ethyl)-piperidin-4-yloxy]-7-methoxy-quinazoline, 4-[(3-chloro-4-fluoro-phenyl)amino]-6-(tetrahydropyran-4-yloxy)-7-ethoxy-quinazoline, 4-[(3-chloro-4-fluoro-phenyl)amino]-6-[[trans-4-[(morpholin-4-yl)carbonylamino]-cyclohexan-1-yloxy]-7-methoxy-quinazoline, 4-[(3-chloro-4-fluoro-phenyl)amino]-6-[[1-[(piperidin-1-yl)carbonyl]-piperidin-4-yloxy]-7-methoxy-quinazoline, 4-[(3-chloro-4-fluoro-phenyl)amino]-6-(cis-4-{N-[(morpholin-4-yl)carbonyl]-N-methyl-amino}-cyclohexan-1-yloxy)-7-methoxy-quinazoline, 4-[(3-chloro-4-fluoro-phenyl)amino]-6-(trans-4-ethansulphonylamino-cyclohexan-1-yloxy)-7-methoxy-quinazoline, 4-[(3-chloro-4-fluoro-phenyl)amino]-6-(1-methanesulphonyl-piperidin-4-yloxy)-7-(2-methoxy-ethoxy)-quinazoline, 4-[(3-chloro-4-fluoro-phenyl)amino]-6-[[1-(2-methoxy-acetyl)-piperidin-4-yloxy]-7-(2-methoxy-ethoxy)-quinazoline, 4-[(3-ethynyl-phenyl)amino]-6-(tetrahydropyran-4-yloxy)-7-methoxy-quinazoline, 4-[(3-chloro-4-fluoro-phenyl)amino]-6-(cis-4-[[N-[(piperidin-1-yl)carbonyl]-N-methyl-amino]-cyclohexan-1-yloxy)-7-methoxy-quinazoline, 4-[(3-chloro-4-fluoro-phenyl)amino]-6-[[cis-4-[(morpholin-4-yl)carbonylamino]-cyclohexan-1-yloxy]-7-methoxy-quinazoline, 4-[(3-chloro-4-fluoro-phenyl)amino]-6-[[1-[2-(2-oxopyrrolidin-1-yl)ethyl]-piperidin-4-yloxy]-7-methoxy-quinazoline, 4-[(3-ethynyl-phenyl)amino]-6-(1-acetyl-piperidin-4-yloxy)-7-methoxy-quinazoline, 4-[(3-ethynyl-phenyl)amino]-6-(1-methyl-piperidin-4-yloxy)-7-methoxy-quinazoline, 4-[(3-ethynyl-phenyl)amino]-6-(1-methanesulphonyl-piperidin-4-yloxy)-7-methoxy-quinazoline, 4-[(3-chloro-4-fluoro-phenyl)amino]-6-(1-methyl-piperidin-4-yloxy)-7-(2-methoxy-ethoxy)-quinazoline, 4-[(3-ethynyl-phenyl)amino]-6-[[1-[(morpholin-4-yl)carbonyl]-piperidin-4-yloxy]-7-methoxy-quinazoline, 4-[(3-chloro-4-fluoro-phenyl)amino]-6-[[1-[(N-methyl-N-2-methoxyethyl-amino)carbonyl]-piperidin-4-yloxy]-7-methoxy-quinazoline, 4-[(3-chloro-4-fluoro-phenyl)amino]-6-(1-ethyl-piperidin-4-yloxy)-7-methoxy-quinazoline, 4-[(3-chloro-4-fluoro-phenyl)amino]-6-[[cis-4-(N-methanesulphonyl-N-methyl-amino)-cyclohexan-1-yloxy]-7-methoxy-quinazoline, 4-[(3-chloro-4-fluoro-phenyl)amino]-6-[[cis-4-(N-acetyl-N-methyl-amino)-cyclohexan-1-yloxy]-7-methoxy-quinazoline, 4-[(3-chloro-

8

4-fluoro-phenyl)amino]-6-(trans-4-methylamino-cyclohexan-1-yloxy)-7-methoxy-quinazoline, 4-[(3-chloro-4-fluoro-phenyl)amino]-6-[[trans-4-(N-methanesulphonyl-N-methyl-amino)-cyclohexan-1-yloxy]-7-methoxy-quinazoline, 4-[(3-chloro-4-fluoro-phenyl)amino]-6-(trans-4-dimethylamino-cyclohexan-1-yloxy)-7-methoxy-quinazoline, 4-[(3-chloro-4-fluoro-phenyl)amino]-6-(trans-4-[[N-[(morpholin-4-yl)carbonyl]-N-methyl-amino]-cyclohexan-1-yloxy]-7-methoxy-quinazoline, 4-[(3-chloro-4-fluoro-phenyl)amino]-6-[[2-(2,2-dimethyl-6-oxo-morpholin-4-yl)-ethoxy]-7-[(S)-(tetrahydrofuran-2-yl)methoxy]-quinazoline, 4-[(3-chloro-4-fluoro-phenyl)amino]-6-(1-methanesulphonyl-piperidin-4-yloxy)-7-methoxy-quinazoline, 4-[(3-chloro-4-fluoro-phenyl)amino]-6-(1-cyano-piperidin-4-yloxy)-7-methoxy-quinazoline, and 4-[(3-chloro-4-fluoro-phenyl)amino]-6-[[1-(2-methoxy-ethyl)carbonyl]-piperidin-4-yloxy]-7-methoxy-quinazoline, optionally in the form of the racemates, enantiomers or diastereomers thereof, optionally in the form of the pharmacologically acceptable acid addition salts thereof, the solvates and/or hydrates thereof.

Examples of acid addition salts with pharmacologically acceptable acids which the compounds may be capable of forming include salts selected from among the hydrochloride, hydrobromide, hydroiodide, hydrosulphate, hydrophosphate, hydromethanesulphonate, hydronitrate, hydromaleate, hydroacetate, hydrobenzoate, hydrocitrate, hydrofumarate, hydrotartrate, hydrooxalate, hydrosuccinate, hydrobenzoate and hydro-p-toluenesulphonate, preferably hydrochloride, hydrobromide, hydrosulphate, hydrophosphate, hydrofumarate and hydromethanesulphonate.

Inhalation is an option for powdered pharmaceutical compositions containing the above-mentioned active substances as well as the salts thereof, esters and combinations of these active substances, salts and esters.

Although the invention herein has been described with reference to particular embodiments, it is to be understood that these embodiments are merely illustrative of the principles and applications of the present invention. It is therefore to be understood that numerous modifications may be made to the illustrative embodiments and that other arrangements may be devised without departing from the spirit and scope of the present invention as defined by the appended claims.

## LIST OF REFERENCE NUMERALS

- 1 lower part
- 2 inspection window
- 3 articulation bolt
- 4 capsule holder
- 5 helical spring
- 6 pin
- 7 double function actuating member (main body)
- 8 recess with sloping side wall as sliding surface
- 9 plate
- 10 screen
- 11 screen holder with retaining lugs
- 12 mouthpiece with gripping aid
- 13 lid
- 14 closure element
- 15 upper rifled surface of 7
- 16 lateral rifled surface of 7
- 17 gripping aid
- 18 guide arms

The invention claimed is:

1. An inhaler for inhaling powdered pharmaceutical compositions from capsules, comprising:

US 7,694,676 B2

9

a lower part,  
 a plate which can be latched to the lower part and with which the lower part can be closed off, and a capsule holder for receiving the capsules, this holder being adapted to be lowered into the lower part,  
 a mouthpiece latchable to the plate,  
 a lid which covers the mouthpiece in a closed position and latches it by means of a closure element, the lower part, the plate, the mouthpiece and the lid being hinged together by means of a single joint, and  
 an actuating member which can be moved out a resting position and thereby interacts with at least one pin which can be made to pierce the capsule holder, wherein:  
 the mouthpiece has a gripping aid by means of which the mouthpiece can be flipped open, away to the side, the gripping aid disposed proximate to an edge of the mouthpiece and proximate to the actuating member when the mouthpiece is closed  
 the actuating member is constructed as a double function actuating member by means of which, in a first actuation, the closure element can be released from the lower part in order to swivel the lid, and with which, in a second actuation, the capsule is pierced, the actuating member including a recess to receive and engage the closure element when the lid covers the mouthpiece in the closed position.

2. The inhaler according to claim 1, wherein the double function actuating member is movably mounted on the plate and/or capsule holder.

3. The inhaler according to claim 1 or 2, wherein in order to assist the opening movement by the double function actuating member a spring element is disposed between the plate and lower part.

4. The inhaler according to claim 1 or 2, wherein the double function actuating member is movably mounted on the plate.

5. The inhaler according to claim 1 or 2, wherein the double function actuating member is spring loaded.

6. The inhaler according to one of claims 1 or 2, wherein the double function actuating member consists of a main body with two parallel guide arms acting thereon.

7. The inhaler according to claim 6, wherein the main body of the double function actuating member comprises an upper rifled surface and at least one lateral rifled surface.

8. The inhaler according to claim 1 or 2, wherein the double function actuating member has on its upper surface a recess which is inclined so as to form a sliding surface for the closure element in the form of a tilting plane.

10

9. The inhaler according to claim 1 or 2, wherein the piercing of the capsule is effected by one or more, preferably two, laterally offset, parallel extending pins which are moved by the actuation of the double function actuating member and perforate the capsule.

10. The inhaler according to claim 9, wherein the pin or pins are guided through tubular pin guides.

11. The inhaler according to claim 9 or 10, wherein the pin or pins are each guided through a laterally mounted guide arm.

12. The inhaler according to claim 11, wherein the guide arms mounted laterally hold the double function actuating member under pre-tension.

13. An inhaler for inhaling powdered pharmaceutical compositions from capsules, comprising:  
 a lower part,  
 a plate which can be latched to the lower part and with which the lower part can be closed off, and a capsule holder for receiving the capsules, this holder being adapted to be lowered into the lower part,  
 a mouthpiece latchable to the plate,  
 a lid which covers the mouthpiece in a closed position and latches it by means of a closure element the lower part, the plate, the mouthpiece and the lid being hinged together by means of a single joint, and  
 an actuating member which can be moved out a resting position and thereby interacts with at least one pin which can be made to pierce the capsule holder,  
 wherein the mouthpiece has a gripping aid by means of which the mouthpiece can be flipped open, away to the side, the gripping aid disposed proximate to an edge of the mouthpiece and proximate to the actuating member when the mouthpiece is closed, the actuating member including a recess to receive and engage the closure element when the lid covers the mouthpiece in the closed position.

14. The inhaler according to claim 13, wherein the gripping aid includes a discontinuity from a smooth contour of the mouthpiece at an upper edge thereof, which forms a projection.

15. The inhaler according to claim 13, wherein the gripping aid is of a size suitable for adult patients.

16. The inhaler according to claim 1 or 13 for inhaling powdered pharmaceutical compositions.

\* \* \* \* \*